



# AS Level Physics

Chapter 5 – Mechanics

5.6.1 Equilibrium

Notes

## EQUILIBRIUM

For forces to be in equilibrium all forces need to be balanced. Coplanar means that forces act in the same plane.

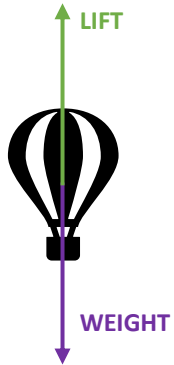

The object can be in equilibrium when two balanced forces act on it with the same magnitude, but in opposite directions. When an object is in equilibrium the resultant force is zero.

Remember zero resultant force does not mean that the object has no force acting on it. Zero resultant force means that the object is either moving with a constant velocity i.e. not accelerating or is stationary (at rest).

If the resultant force is not zero the object will either start to move, accelerate, decelerate or have a turning effect. Therefore the object is not in equilibrium.

## CONDITIONS FOR EQUILIBRIUM

For an object to be in equilibrium the object is **either stationary** or **moving with a constant velocity** and therefore **not accelerating**.

If an object is in equilibrium this means:

- 1) There is no resultant (unbalanced) force acting on it;
- 2) There is no resultant torque acting on it.

## CONDITIONS FOR EQUILIBRIUM

The air balloon opposite has no resultant force and is in equilibrium. This is because for an object to have zero resultant force the horizontal and vertical resultant forces need to be equal. Here:

$$\mathbf{DRAG = THRUST}$$

Horizontal resultant force is zero.

$$\mathbf{LIFT = WEIGHT}$$

Vertical resultant force is also zero.

As the horizontal and vertical forces are both zero the total resultant force acting on the air balloon is zero. Thus **linear acceleration is zero** and the air balloon is in equilibrium.

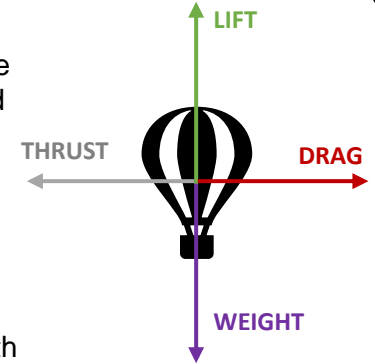

This seesaw with a duck and rooster is in equilibrium because the clockwise moment (rotation) caused by the rooster is equal to the anticlockwise moment (rotation) caused by the duck.

As the clockwise and anticlockwise moments are equal there is no resultant moment (so the seesaw doesn't rotate) and the angular acceleration is zero.

Therefore, the seesaw is in equilibrium making it stationary.

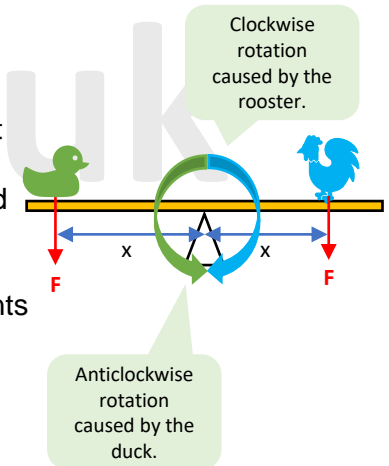

## TRIANGLE OF FORCES

For three coplanar forces in equilibrium we can use the triangle of forces rule:

If an object is in equilibrium and under the action of 3 coplanar forces represented by vectors, they can form a closed right-angled triangle.

This means that the forces can follow each other around to form a triangle e.g.:

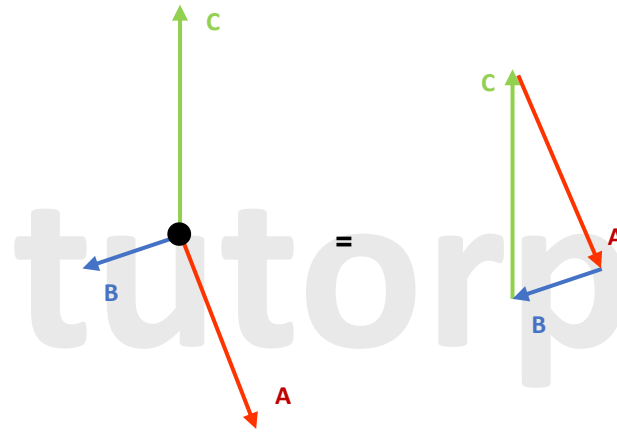

## TRIANGLE OF FORCES

### Example 1:

A metal ball of weight 1.50 N is suspended using a length of wire attached to it.

The ball is then pulled into the position of equilibrium shown in the diagram by a horizontal force of 0.70 N exerted by a bar magnet which is held close to it.

Determine the magnitude and direction of the Tension (T) in the wire.

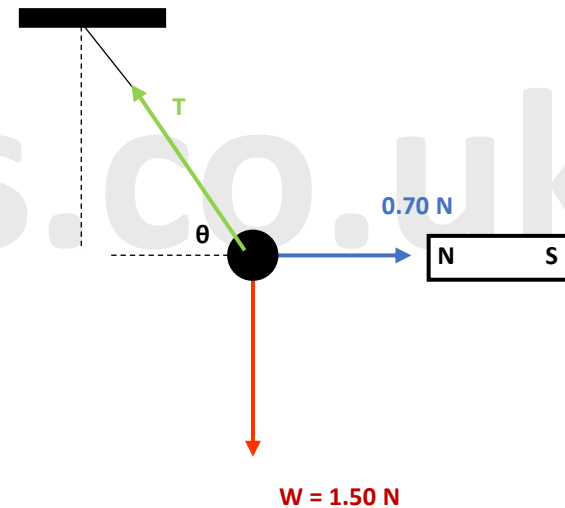

## TRIANGLE OF FORCES

### Example 1:

A metal ball of weight 1.50 N is suspended using a length of wire attached to it.

The ball is then pulled into the position of equilibrium shown in the diagram by a horizontal force of 0.70 N exerted by a bar magnet which is held close to it.

Determine the magnitude and direction of the Tension (T) in the wire

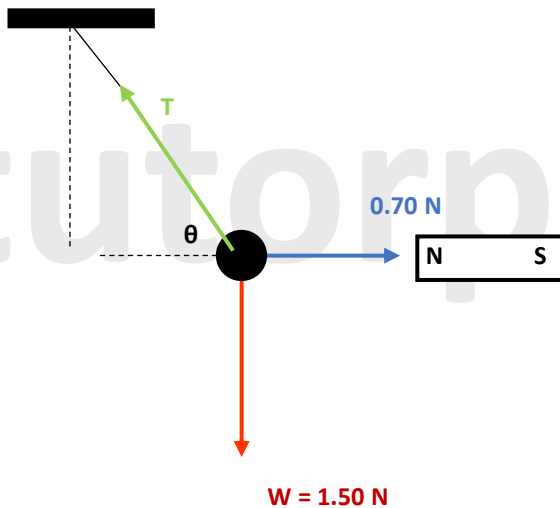

## TRIANGLE OF FORCES

### Example 1:

1) Construct the triangle using the forces from the diagram. As the object is in equilibrium the forces will form a closed right-angled triangle.

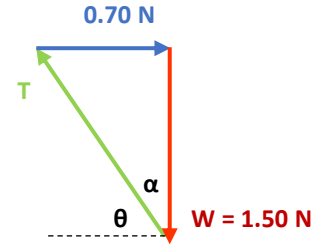

2) Use Pythagoras theorem to calculate the Tension:

$$T = \sqrt{0.70^2 + 1.50^2}$$
$$T = 1.66 \text{ N (2 d.p.)}$$

3) Calculate the direction by using trigonometry.

$$\tan \alpha = \frac{0.70}{1.50}$$

$$\alpha = \tan^{-1} \left( \frac{0.70}{1.50} \right)$$

$$\alpha = 25.02^\circ \text{ (2 d.p.)}$$

$$\text{Therefore } \theta = 90^\circ - 25.02^\circ$$

$$\theta = 64.98^\circ \text{ (2 d.p.)}$$

**Tension = 1.66 N acting at 64.98° to the horizontal.**



## MOMENT OF FORCE

Forces can have many different effects on an object. A moment is the **turning effect** of a force.

- ❖ In simple terms a moment is the force which has the ability to rotate a body/object about a given (fixed) point or a pivot.

Moment can also be referred to as a turning effect or torque.

The moment of a force about a fixed point or pivot is defined as:

$$M = F \times x$$

Where:

- $M$  = Moment of a force measured in Nm.
- $F$  = Magnitude of the force measured in N.
- $x$  = Perpendicular distance from the fixed point or pivot measured in m.

Examples:

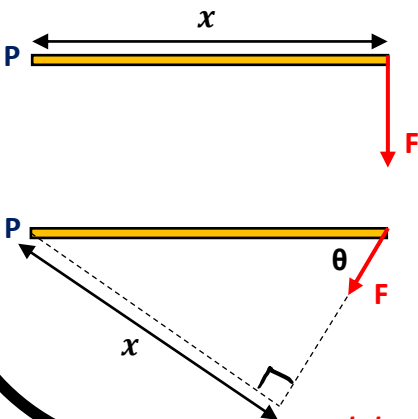

- P is the fixed point or the pivot.
  - $x$  is the perpendicular distance from the fixed point to the force (F).
  - F is the force that will cause the body to rotate.
- To answer moment questions it is very important to be able to determine the perpendicular distance between the pivot and the force.

tutorpacks.co.uk

## MOMENT OF FORCE

### Example 1:

Determine the moment of the 30 N force about the bolt at A.

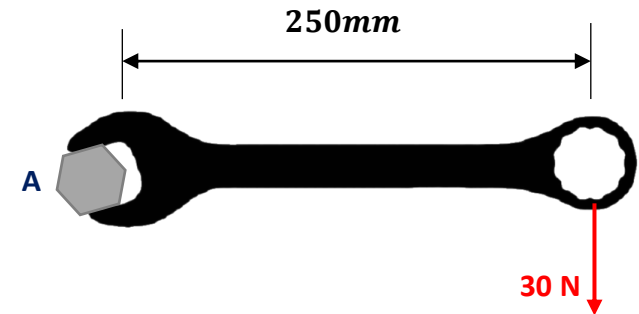

1) Use:

Moment = Force x Perpendicular distance from the pivot (Point A)

2) Calculate the moment:

$$\begin{aligned}M_A &= 30 \text{ N} \times 250 \text{ mm} \\M_A &= 30 \text{ N} \times 0.25 \text{ m} \\M_A &= 7.5 \text{ Nm}\end{aligned}$$

**So the moment is 7.5 Nm.**

tutorpacks.co.uk

## MOMENT OF FORCE

### Example 2:

A force of 150 N acts at an angle of  $30^\circ$  to a beam, and at a distance  $x = 5.0\text{m}$  from one end. What is the moment of the force about this end?

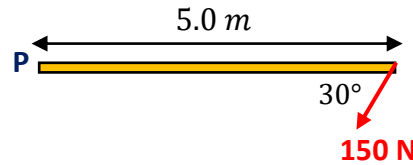

- 1) Draw the line of action of the force. Then draw a perpendicular line from P to the line of action:

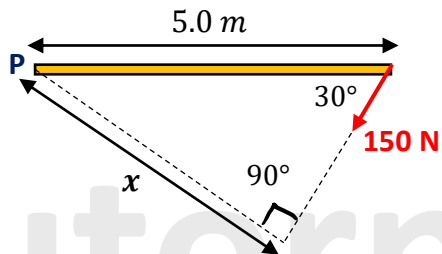

- 2) Calculate the length  $x$  of this line using trigonometry:  
 $x = 5.0\text{ m} \times \sin 30^\circ = 2.5\text{ m}$
- 3) Multiply by the force to find the moment:  
 $\text{moment} = F \times d = 150\text{ N} \times 2.5\text{ m} = 375\text{ Nm}$

Remember the side opposite to the  $90^\circ$  angle is the hypotenuse.

**So the moment is 375 Nm.**

## MOMENT OF FORCE

### Example 3:

Determine the moment of the 5 N force about end A of the beam.

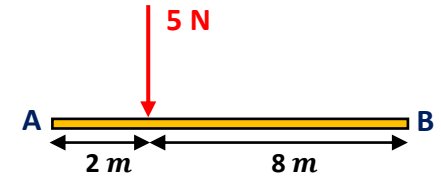

Find the moment about A.

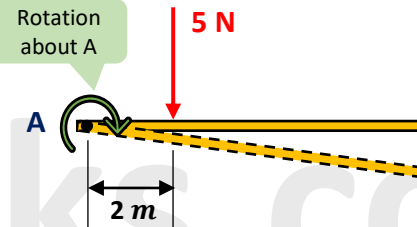

$$\begin{aligned}M &= F \times x \\M &= 5\text{ N} \times 2\text{ m} \\M &= 10\text{ Nm}\end{aligned}$$

**Moment about A is 10 Nm**



## THE PRINCIPLE OF MOMENTS

### Moments are balanced:

The **PRINCIPLE OF MOMENTS** states that for an object/system to be in equilibrium, the sum of the **clockwise moments** about any point is equal to the sum of the **anticlockwise moments** at that point.

To fully understand the Principle of Moments we will need to understand the fact that a moment is a vector component and so it has a magnitude as well as a direction. In this case we can introduce a sign convention to show in which direction the object is turning, i.e.:

- 1) If the object rotates anticlockwise the moment is positive.
- 2) If the object rotates clockwise the moment is negative.

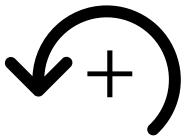

This is the symbol that can be used to show the sign convention where if the object rotates anticlockwise the moment is positive and if the object rotates clockwise the moment is negative.

## THE PRINCIPLE OF MOMENTS

### How to use the sign convention:

Determine the moment of the 5 N force about end A and end B of the beam.

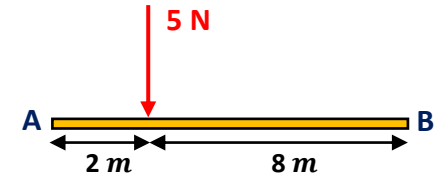

Find the moment about A.

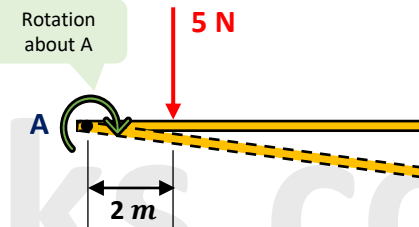

If the beam could rotate freely about point A (no constraint present at B), then a clockwise rotation would be produced.

Sign convention: anticlockwise rotation is positive

$$\begin{aligned} \curvearrowright M_A &= F \times x \\ M &= 5 \text{ N} \times 2 \text{ m} \\ M &= -10 \text{ Nm} \end{aligned}$$

Minus sign because rotation of beam is clockwise

**Moment about A is -10 Nm**

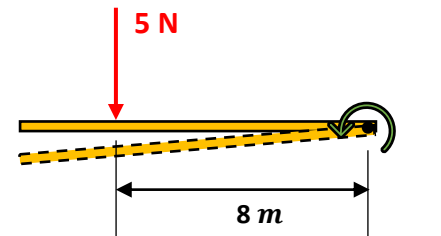

$$\begin{aligned} \curvearrowleft M_B &= F \times x \\ M &= 5 \text{ N} \times 8 \text{ m} \\ M &= +40 \text{ Nm} \end{aligned}$$

Positive sign because rotation of beam is anticlockwise

**Moment about B is 40 Nm**



## THE PRINCIPLE OF MOMENTS

### Example 1:

A duck and a chicken sit on a seesaw as shown in the diagram below. Find the size of the force the chicken applies for the seesaw to be in equilibrium.

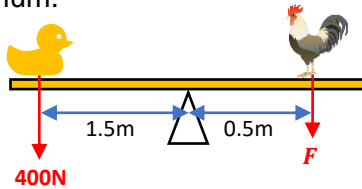

Before answering the question you need to understand the question first. Now if the seesaw is in equilibrium then we can use the **principle of moments** that states, in equilibrium **sum of the anticlockwise moment is equal to the sum of the clockwise moment**. So we have to calculate the force the chicken needs to exert to keep the seesaw in equilibrium.

- 1) Set up a coordinate system: ↺ lets say anticlockwise rotation is positive and downwards force is positive.
- 2) Understand where the pivot is. In this case it is in the middle of the seesaw where the triangle stand is.
- 3) Look at each force individually and figure out in which direction each force causes the seesaw to rotate.
- 4) As the seesaw is in equilibrium we know that the sum of the clockwise and sum of the anti-clockwise moments should **equal to zero**.
- 5) Knowing this we can write:  

$$\text{In equilibrium: } \sum \text{ anticlockwise moments} = \sum \text{ clockwise moment}$$
- 6) So  

$$\text{In equilibrium: } \sum \text{ anticlockwise moments} - \sum \text{ clockwise moment} = 0$$
- 7) Rearrange the equation to determine the final value.

Σ means "sum of"

## THE PRINCIPLE OF MOMENTS

### Example 1:

If the beam could rotate freely about the pivot, the duck causes the seesaw to **rotate anticlockwise**.

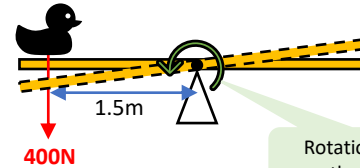

Rotation about the pivot

$$\begin{aligned} \curvearrowright M_{Duck} &= F \times x \\ M &= 400 \text{ N} \times 1.5 \text{ m} \\ M &= +600 \text{ Nm} \end{aligned}$$

Sign convention indicates anticlockwise rotation is positive

Positive sign because rotation of beam is anticlockwise

If the beam could rotate freely about the pivot, the rooster causes the seesaw to **rotate clockwise**.

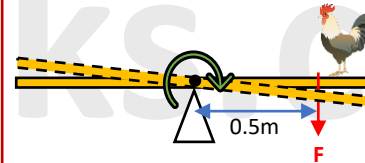

$$\begin{aligned} \curvearrowleft M_{Rooster} &= F \times x \\ M &= F \times 0.5 \text{ m} \\ M &= -0.5F \text{ Nm} \end{aligned}$$

Minus sign because rotation of beam is clockwise

$$\text{In equilibrium } \sum \text{ anticlockwise moments} - \sum \text{ clockwise moment} = 0$$

$$\begin{aligned} M_{Duck} + M_{Rooster} &= 0 \\ +600 \text{ Nm} - 0.5F \text{ Nm} &= 0 \\ 0.5F &= 600 \\ F &= 1200 \text{ N} \end{aligned}$$

This means the chicken is applying a force of 1200N to keep the seesaw balanced



## THE PRINCIPLE OF MOMENTS

### Levers:

A lever is a plank or a rigid beam that is free to rotate on a pivot. A lever is a great tool for lifting or moving very heavy objects. Examples of levers include wheelbarrows, shovels, seesaw or crowbar.

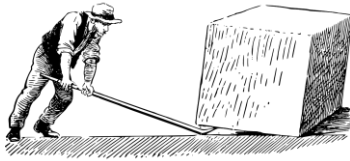

Even your arm can be considered a lever.

Exam papers love to test your understanding of the principle of moments based around an arm. Remember in those questions:

- The muscle provides the upwards force (effort force) in order to hold a load/weight up with your hand.
- The joint acts as the pivot.
- The rigid beam joining the muscle to the joint to the weight is the bone.



### Tip:

To answer complicated moments question, simplify the diagram into a simple beam (see next page).

[tutorpacks.co.uk](http://tutorpacks.co.uk)

## THE PRINCIPLE OF MOMENTS

### Example 1:

Find the force exerted by the biceps in holding a ball (**E**). The ball weighs 100 N and the forearm weighs 20 N.

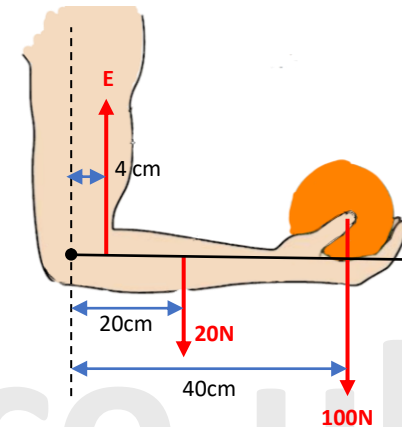

### Remember:

- Use the principle of moments
- Set up a coordinate system where anticlockwise moment is positive
- *In equilibrium*  $\sum \text{anticlockwise moments} - \sum \text{clockwise moments} = 0$
- Simplify question into a simple beam to make the question easier to answer

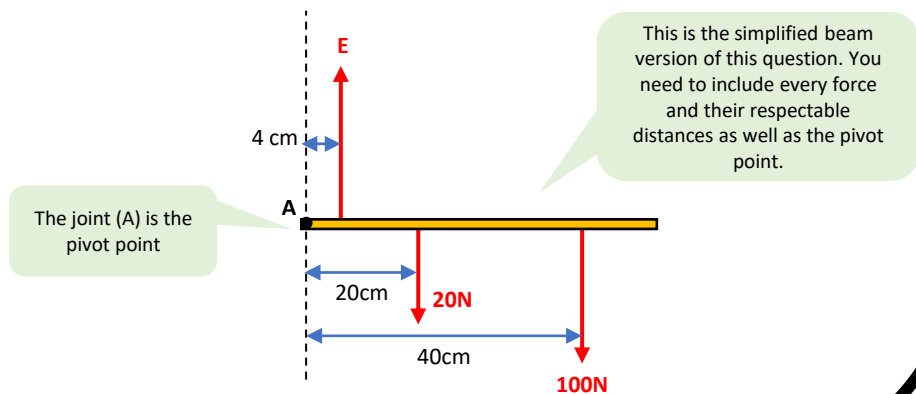

[tutorpacks.co.uk](http://tutorpacks.co.uk)



## THE PRINCIPLE OF MOMENTS

### Example 1:

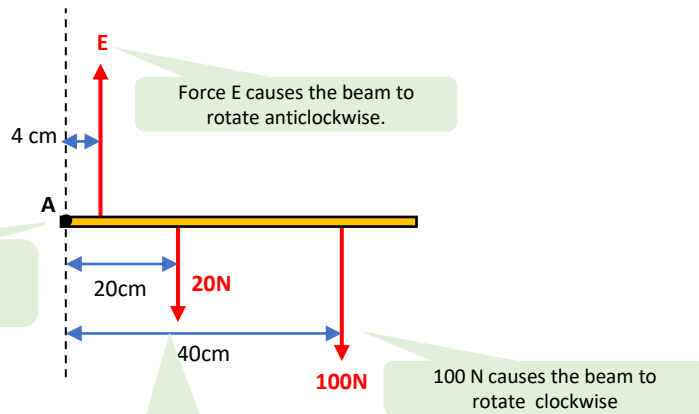

A is the pivot point. This is where the rotation will take place.

Force E causes the beam to rotate anticlockwise.

20 N force causes the beam to rotate clockwise.

100 N causes the beam to rotate clockwise

In equilibrium  $\sum \text{anticlockwise moments} - \sum \text{clockwise moments} = 0$

Sign convention: anti-clockwise rotation is positive

$$\curvearrowright M_E - M_{20N} - M_{100N} = 0$$

$M_E$  = moment of force E  
 $M_{20N}$  = moment of 20N force  
 $M_{100N}$  = moment of 100N force

$$+(0.04m)(E) - (20\text{ N})(0.20m) - (100\text{ N})(0.4m) = 0$$

Positive sign because rotation of beam is anti-clockwise

$$0.04E - 4 - 40 = 0$$

Minus sign because rotation of beam is clockwise

$$0.04E = 44$$

$$E = 1100\text{ N}$$

## THE PRINCIPLE OF MOMENTS

Continue to the next page.



## COUPLES

### Equal, opposite and parallel forces that cause rotation

- A couple consists of **two equal forces** which act **parallel** to each other but in **opposite directions**.
- Because the forces are equal but opposite there is **no resultant linear force**. However, the two equal and opposite forces do produce a **turning force**.
- This turning force is usually referred to as a **torque** rather than a moment.

You can calculate the torque of a couple using the formula below:

$$T = F \times d$$

Where:

- $T$  = torque of a couple measured in Nm
- $F$  = size of one of the forces measured in N
- $d$  = perpendicular distance between the forces measured in m

You might notice both Torque and Moment have the same formula and the same units.

In physics torque and moment signify the same thing where a force rotates the body to which it is applied.

However, in mechanics they have slightly different meanings. Both still have the same units however torque is a movement force whereas moment is a static force. Torque is used where there is rotation involved, whereas moment is used where there is no rotation.



## COUPLES

The diagram below shows a ship wheel which is free to rotate. If two equal, opposite, parallel forces ( $F$ ) act as shown, an anticlockwise TORQUE ( $T$ ) is produced.

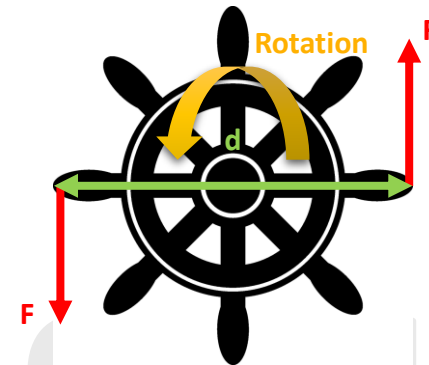

## COUPLES

### Example 1:

Calculate the TORQUE produced by the forces shown in the diagram opposite:

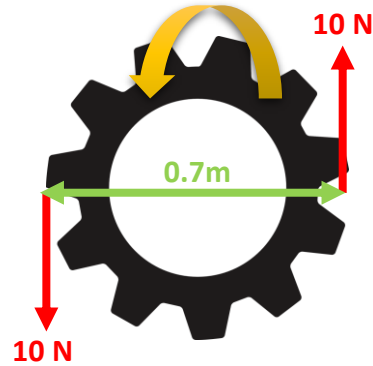

Use:  $T = F \times d$

Only use the size of one of the forces.

$$T = 10\text{ N} \times 0.7\text{ m}$$

This is the perpendicular distance between the forces

$$T = 7\text{ Nm}$$

## COUPLES

### Example 2:

Calculate the TORQUE produced by the forces shown in the diagram opposite:

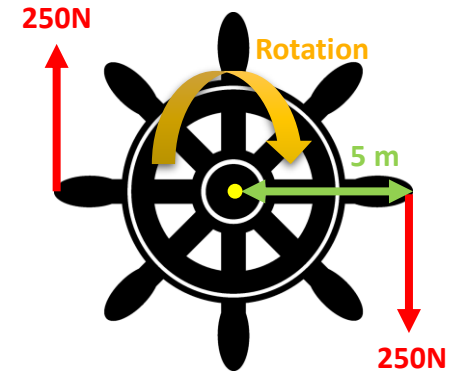

Use:  $T = F \times d$

$$T = 250\text{ N} \times 10\text{ m}$$

This is the perpendicular distance between the forces so you have to double the distance between the forces e.g.  $5\text{ m} + 5\text{ m} = 10\text{ m}$

$$T = 2500\text{ Nm}$$



## CENTRE OF GRAVITY

The centre of gravity (or the centre of mass) of an object is the single point at which we can consider its entire weight to act through. In other words a single point where all the mass is concentrated.

You can find the centre of gravity by using symmetry for regular shapes or experimentally for regular and irregular shapes.

### Finding the centre of gravity for an irregular object

- 1) Freely suspend an object from one corner.
- 2) Then using a plumb, draw a vertical line downwards from the point of suspension.
- 3) Now pick another corner to suspend the object.
- 4) Draw another vertical line downwards.
- 5) Where the two lines intersect is where the centre of gravity for the object is located.

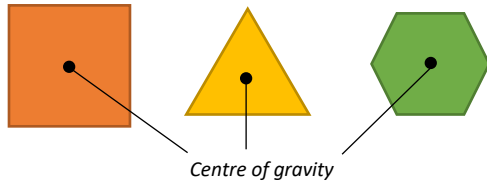
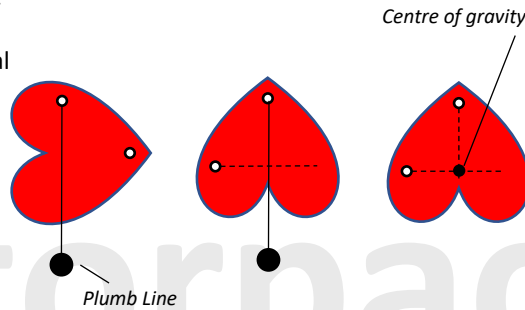

For a regular object you can just use symmetry. The centre of gravity of any regular shape is at its centre.

### Stability

- 1) Stable objects have low centre of gravity and a wide base area.
- 2) Objects will topple over if the line of action from the centre of gravity falls outside the objects base area:

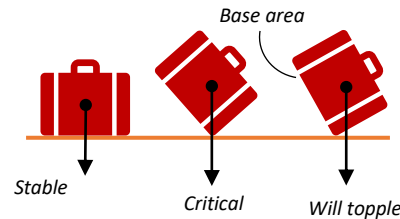

## CENTRE OF GRAVITY

### **Exam Style Question 1:**

Fig 4.1 shows an irregular shaped metal plate of constant thickness that can swing freely about point P.

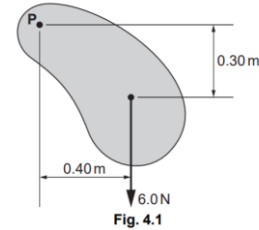

- a) State what is meant by the centre of gravity of an object.
- b) Describe an experiment to determine the centre of gravity of the metal plate shown in Fig. 4.1.

### **Answer:**

- a) A point where the entire weight of the object appears to act.
- b) Step 1: Suspend the metal plate from a point and then mark a vertical line on the plate. A plumb line or a pendulum can be used to find the vertical line.  
Step 2: Hang the plate from another point and draw another vertical line.  
Step 3: Where the lines intersect gives you the position of the centre of gravity.

Please see **'5.6.2 Equilibriums Worked Examples'**  
pack for exam style questions.

For more revision notes, tutorials, worked  
examples and more help visit  
[www.tutorpacks.co.uk](http://www.tutorpacks.co.uk).

