



AS Level Physics

Chapter 3 – Electric Circuits

3.3.2 Resistance and Resistivity

Worked Examples

RESISTANCE & OHM'S LAW

Exam Style Question 1

a) State Ohm's law in words.

A student connects a circuit to find the resistance of a washing machine heating element.

b) Complete the circuit diagram below and explain how he uses it to obtain the necessary measurements to calculate the resistance.

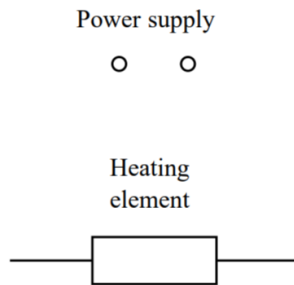

c) The following results are obtained.

Voltage = 3.00 V

Current = 0.12 A

Calculate the resistance of the element from these values.

RESISTANCE & OHM'S LAW

Exam Style Question 1

a) States Ohms law in words.

Current is directly proportional to p.d. for a metal conductor provided temperature and all physical conditions remains constant.

b) Complete the circuit diagram below and explain how he uses it to obtain the necessary measurements to calculate the resistance.

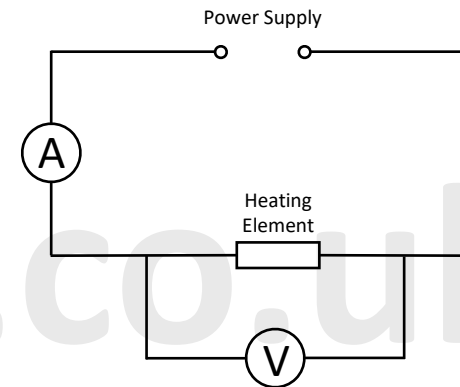

Connect the ammeter in series and voltmeter in parallel to the heating element. The current can be measured using the ammeter and the p.d. can be measured using the voltmeter. Then use $R = \frac{V}{I}$ to calculate the resistance.

c) Calculate the resistance of the element from these values.

Use: $R = \frac{V}{I}$

$$R = \frac{3.00 \text{ V}}{0.12 \text{ A}}$$
$$\therefore R = 25.0 \Omega$$



RESISTANCE & OHM's LAW

Exam Style Question 2

- a) On the axes below draw the I – V characteristic for a silicon semiconductor diode in both forward bias and reverse bias. Indicate any relevant voltage values on the axis.

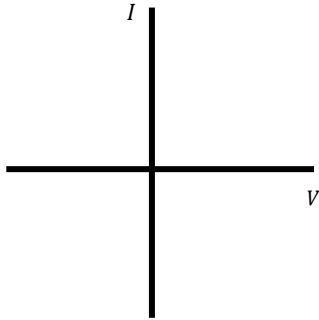

- b) The figure below shows the I – V characteristic for a filament lamp. Explain the shape of the characteristic.

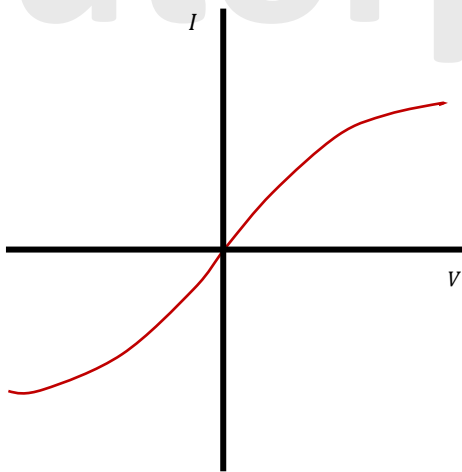

RESISTANCE & OHM's LAW

Exam Style Question 2

- a) On the axes below draw the I – V characteristic for a silicon semiconductor diode in both forward bias and reverse bias. Indicate any relevant voltage values on the axis.

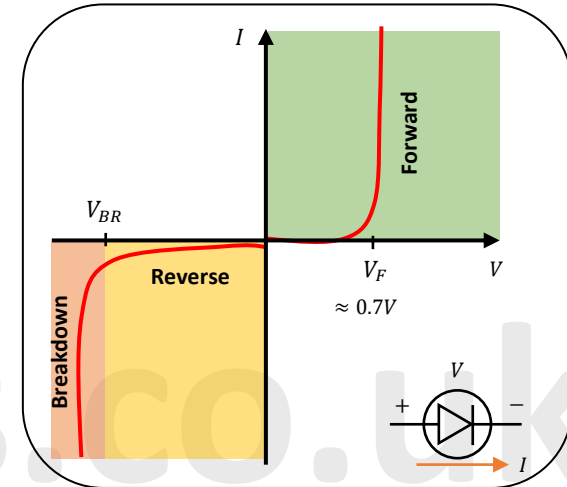

Diodes are expected to stop all current in the opposite direction and serve as a short-circuit in the forward current, but this isn't always the case because diode behaviour is not perfect.

A diode can operate in one of three states depending on the voltage put across it.

- 1) **Forward bias:** When the voltage is positive and greater than the threshold voltage (V_F), the diode is "on", allowing the current to flow.
- 2) **Reverse bias:** When the voltage is less than V_F but more than V_{BR} , the diode is in "off" mode, stopping current flow. A very little amount of current can flow in reverse through the diode, known as reverse saturation current.
- 3) **Breakdown:** If a large negative voltage (breakdown voltage) is applied to the diode, it will give in and allow current to flow in the opposite direction. Certain diodes are engineered to operate in the breakdown area, but most diodes are not suitable for high negative voltages.

The breakdown voltage of a typical diode is approx. -50 V to -100 V , or lower.

RESISTANCE & OHM'S LAW

Exam Style Question 2

- a) On the axes below draw the $I - V$ characteristic for a silicon semiconductor diode in both forward bias and reverse bias. Indicate any relevant voltage values on the axis.

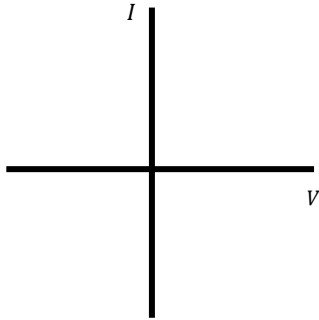

- b) The figure below shows the $I - V$ characteristic for a filament lamp. Explain the shape of the characteristic.

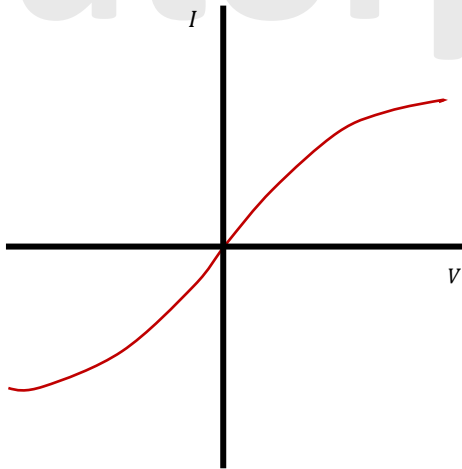

RESISTANCE & OHM'S LAW

Exam Style Question 2

- b) The figure below shows the $I - V$ characteristic for a filament lamp. Explain the shape of the characteristic.

At low V , I increases proportionally and Ohm's law is obeyed. However, as V increases, I increases which also increases the temperature of the filament resulting the resistance to increase. This increase in the temperature means temperature is no longer constant and the filament lamp will no longer obey Ohm's law.

RESISTANCE & OHM'S LAW

Exam Style Question 3

The diagram below shows how the resistance of a thermistor varies with temperature.

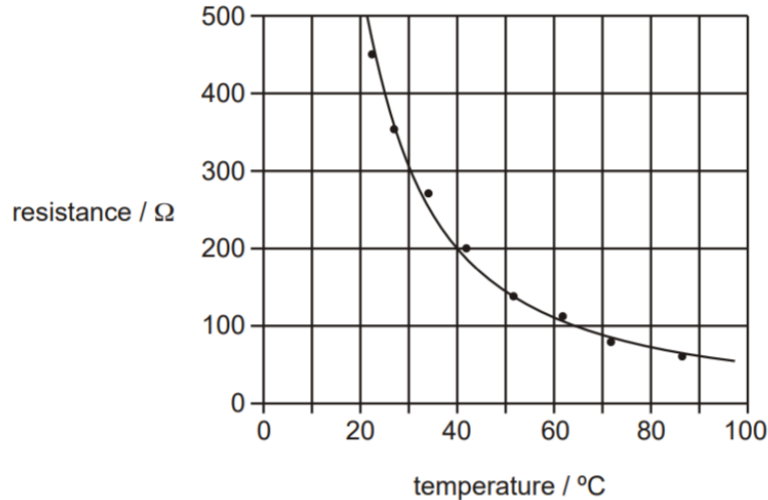

- Describe qualitatively how the resistance of the thermistor changes as the temperature rises.
- The change in resistance between 80°C and 90°C is about $15\ \Omega$.

State the change in resistance between 30°C and 40°C .

- Describe, giving a reason, how the sensitivity of temperature measurement using this circuit changes over the range of temperature shown on the diagram.



RESISTANCE & OHM'S LAW

Exam Style Question 3

- Describe qualitatively how the resistance of the thermistor changes as the temperature rises.**

Resistance decreases with an increase in temperature.

- State the change in resistance between 30°C and 40°C .**

Resistance at $30^{\circ}\text{C} = 300\ \Omega$

Resistance at $40^{\circ}\text{C} = 200\ \Omega$

So the change in resistance is $= 300\ \Omega - 200\ \Omega = 100\ \Omega$

- Describe, giving a reason, how the sensitivity of temperature measurement using this circuit changes over the range of temperature shown on the diagram.**

For low temperatures ΔR is large for $\Delta\theta$ and at high temperatures ΔR is small for the same $\Delta\theta$ therefore sensitivity decreases continuously from low to high temperature.

RESISTANCE & OHM'S LAW

Exam Style Question 4

Fig. 1 shows how the resistance of a thermistor varies with temperature.

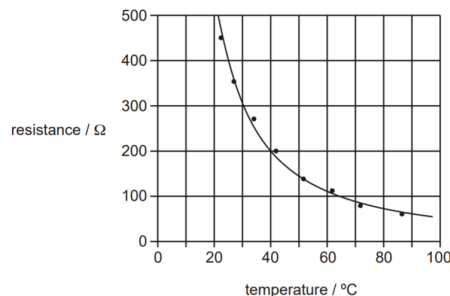

Fig. 2 below shows a temperature sensing potential divider circuit where this thermistor may be connected, between terminals A and B, in series with a resistor.

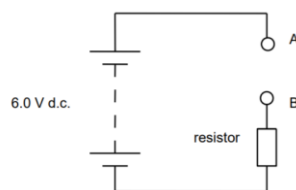

Fig. 2

- Draw the circuit symbol for a thermistor on Fig. 2 in the space between terminals A and B.
- A voltmeter is to be connected to the circuit to indicate an increasing p.d. when the thermistor detects an increasing temperature. On Fig. 2, draw the circuit connections for a voltmeter to measure a p.d. that rises with increasing temperature.
- The value of the resistor in Fig. 2 is $200\ \Omega$. The thermistor is at 65°C . Use data from Fig. 1 to show that the current in the circuit is about $0.02\ \text{A}$.
- Calculate the p.d. across the $200\ \Omega$ resistor at 65°C .

RESISTANCE & OHM'S LAW

Exam Style Question 4

- Draw the circuit symbol for a thermistor on Fig. 2 in the space between terminals A and B.
- On Fig. 2, draw the circuit connections for a voltmeter to measure a p.d. that rises with increasing temperature.

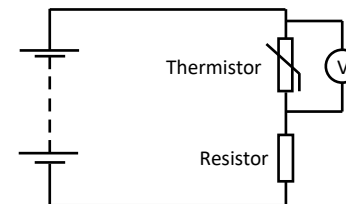

- Use data from Fig. 1 to show that the current in the circuit is about $0.02\ \text{A}$.

We know the thermistor is at 65°C therefore the resistance of the thermistor is $100\ \Omega$ using Fig. 1.

Use: $V = IR$ but because we have two components in series with each other with their own resistance we need to find out the total resistance.

As the components are in series you just need to add the two resistances together to get the total resistance:

$$\begin{aligned} R_{total} &= R_{thermistor} + R_{resistor} \\ R_{total} &= 100\ \Omega + 200\ \Omega \\ R_{total} &= 300\ \Omega \end{aligned}$$

Therefore:

$$\begin{aligned} V &= IR \\ I &= \frac{V}{R_{total}} = \frac{6\ \text{V}}{300\ \Omega} = 0.02\ \text{A} \end{aligned}$$

- Calculate the p.d. across the $200\ \Omega$ resistor at 65°C .

We just need to calculate the p.d. across the resistor therefore use $V = IR$

$$V = IR = (0.02\ \text{A})(200\ \Omega) = 4.0\ \text{V}$$

So the p.d. across the resistor is $4.0\ \text{V}$.

RESISTANCE & OHM'S LAW

Exam Style Question 5

The current-potential difference characteristic of an electrical component are shown below.

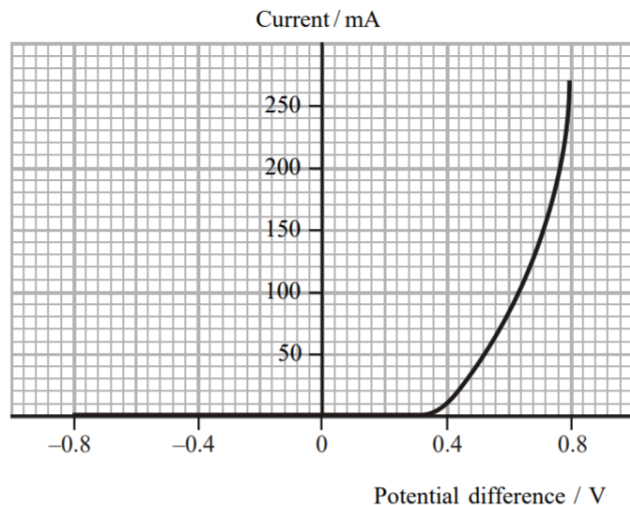

- Name the component.
- Calculate the resistance of this component when the potential difference is $+0.60\text{ V}$.
- State the resistance when the potential difference is -0.80 V .
- State the practical use for this component.



RESISTANCE & OHM'S LAW

Exam Style Question 5

a) Name the component.

LED or Diode

b) Calculate the resistance of this component when the potential difference is $+0.60\text{ V}$.

Use: $V = IR$ and rearrange for $R = \frac{V}{I}$

At $+0.60\text{ V}$ you can use the graph to calculate the I .

At $+0.60\text{ V}$ the current I is $85 \times 10^{-3}\text{ A}$.

$$R = \frac{V}{I} = \frac{0.60\text{ V}}{85 \times 10^{-3}\text{ A}}$$
$$R = 7.06\ \Omega$$

bii) State the resistance when the potential difference is -0.80 V .

Infinite

c) State the practical use for this component.

A diode can be used to:

- Stabilise power output
- Protect components

An LED can be used in a:

- Torch
- Calculator display

RESISTANCE & OHM'S LAW

Exam Style Question 6

The graph shows the I–V characteristics for two conductors. One is a length of nichrome wire and the other is the tungsten filament of a lamp.

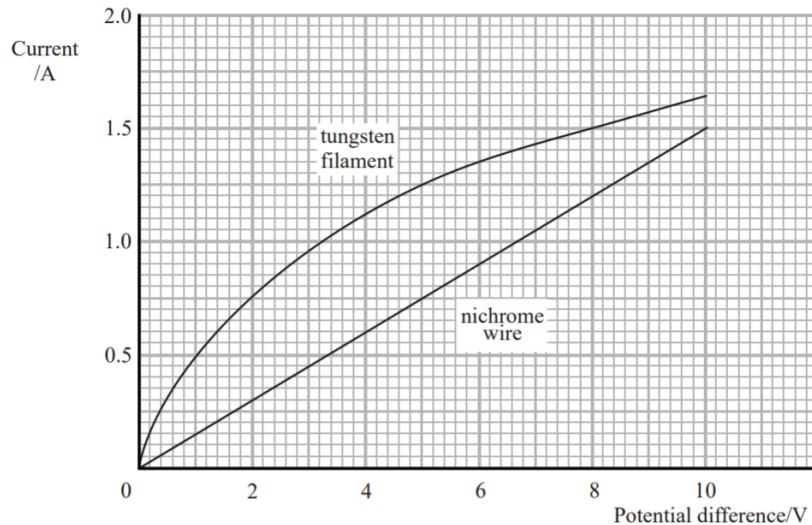

- a) Making reference to Ohm's law, explain the shape of the tungsten filament graph.
- b) Calculate the resistance of the tungsten filament when the potential difference across it is 8.0 V.



RESISTANCE & OHM'S LAW

Exam Style Question 6

a) Referring to Ohm's law, explain the shape of the tungsten filament graph.

I is not directly proportional to V , therefore, the tungsten filament does not obey Ohm's law and so it makes it a non ohmic conductor. This means the temperature is not constant. As the current increases the temperature of the filament also increases. As a result, the resistance increases. This increase in temperature is the reason why the filament doesn't obey Ohm's law.

b) Calculate the resistance of the tungsten filament when the potential difference across it is 8.0 V.

Use: $V = IR$ and rearrange for R .

We have the p.d. and using that we can find out the current from the graph.

Therefore at 8.0 V the current is 1.5 A.

$$R = \frac{V}{I} = \frac{8.0 \text{ V}}{1.5 \text{ A}} = 5.3 \Omega$$

RESISTANCE & OHM'S LAW

Exam Style Question 7

A student does some measurements on two light-emitting diodes (LEDs). She measures the current I through them at a series of voltages V . Her results are shown in the table.

V/V	Green LED I/mA	Red LED I/mA
1.1	0	0
1.2	0	0
1.3	0	0
1.4	0	0.01
1.5	0	0.05
1.6	0	0.33
1.7	0.02	3.89
1.8	0.20	
1.9	1.46	
2.0	5.12	

a) Complete the circuit diagram below to show a circuit that she could have used to obtain these results.



b) For both LEDs, the current varies in a similar way. Describe in words this variation.

c) Discuss whether the LEDs obey Ohm's law.

d) Calculate the resistance of the green LED when it has 1.9 V across it.

e) Calculate the power dissipated by the red LED when it has 1.7 V across it.

RESISTANCE & OHM'S LAW

Exam Style Question 7

a) Complete the circuit diagram below to show a circuit that she could have used to obtain these results.

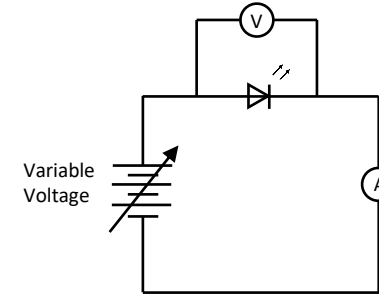

b) For both LEDs, the current varies in a similar way. Describe in words this variation.

Initially, increasing voltage gives zero current and so current doesn't flow until a specific minimum voltage is achieved. At that minimum voltage current increases.

c) Discuss whether the LEDs obey Ohm's law.

No, I is not proportional to V .

d) Calculate the resistance of the green LED when it has 1.9 V across it.

Use: $R = \frac{V}{I}$. You can get the V and I from the table:

$$R = \frac{1.9 \text{ V}}{1.46 \times 10^{-3} \text{ A}}$$

$$R = 1301.3698 \dots \Omega$$

$$R = 1301 \Omega$$

e) Calculate the power dissipated by the red LED when it has 1.7 V across it.

$$P = IV$$

$$P = (3.89 \times 10^{-3} \text{ A})(1.7 \text{ V})$$

$$P = 6.6 \times 10^{-3} \text{ W}$$

Resistance and Temperature

Exam Style Question 8

A group of students is discussing why the resistance of the metal filament of a lamp and the resistance of an NTC thermistor respond differently to changes in temperature.

One student says that the increased vibrations of the atoms affect the conduction process.

Another student says that as the temperature increases more electrons can break free of the atoms and take part in conduction. Both students are correct.

Explain how these two effects apply to the lamp and the thermistor

Resistance and Temperature

Exam Style Question 8

Explain how these two effects apply to the lamp and the thermistor.

For the lamp:

Increased atomic vibrations is caused by the increase in the temperature which reduces the movement of electrons. The reduced movement of electrons causes the resistance of the lamp to increase. This means the resistance of the lamp increases with temperature.

For the thermistor:

Increased atomic vibrations still occur and still reduce the movement of electrons. But the increase in temperature leads to a large increase in n (number density). Therefore, using $I = nqvA$, as n increases so does the current. Overall, the resistance of the thermistor decreased with increase in temperature.



Resistance and Temperature

Exam Style Question 9

- ai) Define electrical resistivity.
- aii) Explain why the resistivity rather than the resistance of a material is given in tables of properties of materials.

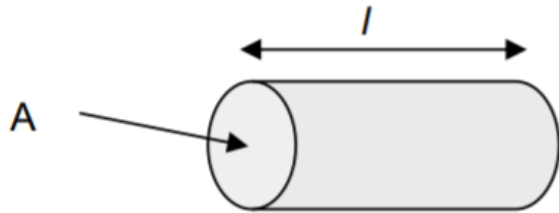

The diagram above shows a copper rod of length $l = 0.080 \text{ m}$, having a cross-sectional area $A = 3.0 \times 10^{-4} \text{ m}^2$.

The resistivity of copper is $1.7 \times 10^{-8} \Omega \text{ m}$.

- b) Calculate the resistance between the ends of the copper rod.

Resistance and Temperature

Exam Style Question 9

- ai) Define electrical resistivity.**

The resistivity of a material is defined as the resistance of unit length with unit cross-sectional area.

$$\rho = \frac{RA}{L}$$

Where:

R = Resistance measured in Ohms, Ω .

ρ = Resistivity measured in Ohm-metres, $\Omega \text{ m}$.

L = Length measured in metres, m.

A = Cross-sectional area measured in metres squared, m^2 .

- aii) Explain why the resistivity rather than the resistance of a material is given in tables of properties of materials.**

The resistivity is constant for a given material and is independent of dimensions of the specimen of the material.

- b) Calculate the resistance between the ends of the copper rod.**

Use: $R = \frac{\rho L}{A}$

$$R = \frac{(1.7 \times 10^{-8} \Omega \text{ m})(0.080 \text{ m})}{3.0 \times 10^{-4} \text{ m}^2}$$
$$R = 4.53 \times 10^{-6} \Omega$$



Resistance and Temperature

Exam Style Question 10

- a) A metal wire of length 1.4 m has a uniform cross-sectional area = $7.8 \times 10^{-7} \text{ m}^2$. Calculate the resistance, R , of the wire.

resistivity of the metal = $1.7 \times 10^{-8} \Omega \text{ m}$

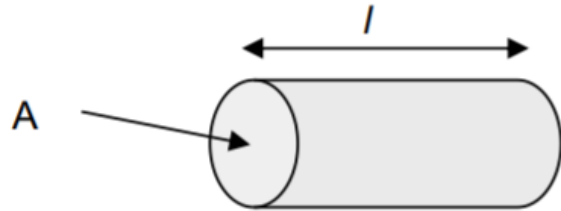

- b) The wire is now stretched to twice its original length by a process that keeps its volume constant. If the resistivity of the metal of the wire remains constant, show that the resistance increases to $4R$.

Resistance and Temperature

Exam Style Question 10

- a) Calculate the resistance, R , of the wire.

Use: $R = \frac{\rho L}{A}$

$$R = \frac{(1.7 \times 10^{-8} \Omega \text{ m})(1.4 \text{ m})}{7.8 \times 10^{-7} \text{ m}^2}$$
$$R = 0.031 \Omega$$

- b) If the resistivity of the metal of the wire remains constant, show that the resistance increases to $4R$.

$$R = \frac{\rho L}{A}$$

L is twice the original length however volume is kept constant. So:

$$\text{Volume} = A \times L$$

If L is twice the original length that would mean the total volume will also be twice as big. However, we want the volume to stay constant. So the cross-sectional area, A will need to be half the size (or divided by 2). Example:

$$\text{Volume} = \frac{A}{2} \times 2L$$

$$\text{Volume} = \frac{A}{2} \times \cancel{2}L$$

You can see the 2 cancels out and the volume remains constant. Knowing this information, divide A by 2 and times L by 2 and you can find resistance:

$$R = \frac{\rho \times 2L}{\frac{A}{2}}$$

$$\therefore R = 4 \left(\frac{\rho L}{A} \right)$$

Which in turn means resistance increases to $4R$.



Resistance and Temperature

Exam Style Question 11

- a) A sample of conducting putty is rolled into a cylinder which is $6.0 \times 10^{-2} \text{ m}$ long and has a radius of $1.2 \times 10^{-2} \text{ m}$.

resistivity of the putty = $4.0 \times 10^{-3} \Omega \text{ m}$.

- i) Calculate the resistance between the ends of the cylinder of conducting putty.
- ii) The putty is now reshaped into a cylinder with half the radius and a length which is four times as great. Determine how many times greater the resistance now is.
- b) Given the original cylinder of the conducting putty described in part (a), describe how you would use a voltmeter, ammeter and other standard laboratory equipment to determine a value for the resistivity of the putty.
- Your description should include
 - a labelled circuit diagram,
 - details of the measurements you would make,
 - an account of how you would use your measurements to determine the result,
 - details of how to improve the precision of your measurements.

The quality of your written communication will be assessed in this question.



Resistance and Temperature

Exam Style Question 11

- ai) Calculate the resistance between the ends of the cylinder of conducting putty.

$$\text{Use: } R = \frac{\rho L}{A}$$

We don't have A but we know it is a cylinder so to calculate the cross-sectional area of the cylinder we use the formula to calculate the area of a circle:

$$\begin{aligned} A_{\text{circle}} &= \pi r^2 \\ A_{\text{circle}} &= \pi (1.2 \times 10^{-2} \text{ m})^2 \\ A_{\text{circle}} &= 4.52389 \dots \times 10^{-4} \text{ m}^2 \end{aligned}$$

Now substitute that back into $R = \frac{\rho L}{A}$:

$$R = \frac{(4.0 \times 10^{-3} \Omega \text{ m})(6.0 \times 10^{-2} \text{ m})}{4.52389 \dots \times 10^{-4} \text{ m}^2}$$
$$R = 0.53 \Omega$$

- aii) Determine how many times greater the resistance now is.

$$\text{Use: } R = \frac{\rho L}{A}$$

Substitute the area for πr^2

Therefore:

$$R = \frac{\rho L}{(\pi r^2)}$$

But the length increases by 4 and the radius is halved:

$$R = \frac{\rho \times 4L}{\left(\pi \times \left(\frac{r}{2}\right)^2\right)} = \frac{\rho \times 4L}{\pi \times \frac{r^2}{4}} = \frac{4(\rho L)}{\frac{1}{4}(\pi \times r^2)}$$
$$R = \frac{16(\rho L)}{(\pi r^2)}$$

Therefore: $R = 16R$

So the resistance will be 16 times greater.

Resistance and Temperature

Exam Style Question 11

- a) A sample of conducting putty is rolled into a cylinder which is $6.0 \times 10^{-2} \text{ m}$ long and has a radius of $1.2 \times 10^{-2} \text{ m}$.

resistivity of the putty = $4.0 \times 10^{-3} \Omega \text{ m}$.

- i) Calculate the resistance between the ends of the cylinder of conducting putty.
- ii) The putty is now reshaped into a cylinder with half the radius and a length which is four times as great. Determine how many times greater the resistance now is.
- b) Given the original cylinder of the conducting putty described in part (a), describe how you would use a voltmeter, ammeter and other standard laboratory equipment to determine a value for the resistivity of the putty.
- Your description should include
 - a labelled circuit diagram,
 - details of the measurements you would make,
 - an account of how you would use your measurements to determine the result,
 - details of how to improve the precision of your measurements.

The quality of your written communication will be assessed in this question.

Resistance and Temperature

Exam Style Question 11

- b) Describe how you would use a voltmeter, ammeter and other standard laboratory equipment to determine a value for the resistivity of the putty.

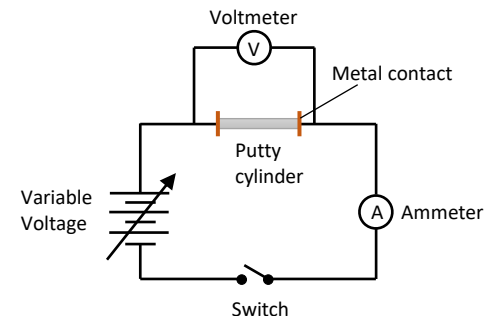

- Step 1: Measure the length of the putty with a ruler.
- Step 2: Measure the diameter or thickness with a micrometre.
- Step 3: Close the switch and measure the voltage using the voltmeter and current using an ammeter.
- Step 4: Calculate the resistance using: $R = \frac{V}{I}$
- Step 5: Change the voltage and carry out steps 3 and 4.
- Step 6: Put the values on a I/V graph and use the graph to calculate the gradient which will give you the resistance R .
- Step 7: Calculate the cross-sectional area using the diameter of the putty.
- Step 8: Use $\rho = \frac{RA}{L}$ to calculate the resistivity.

To improve the precision of the measurements use flat metal electrodes at each end to improve connection. Use vernier callipers and pick three different points on the putty to measure the diameter and calculate the mean. Use a digital voltmeter and ammeter rather than an analogue.

Resistance and Temperature

Exam Style Question 12

- a) Give an expression for the resistivity of a material in the form of a uniform wire. Define all the symbols used.
- b) A thin film of carbon may be used in some electronic systems. Typical dimensions of such a film are shown in Figure 1.

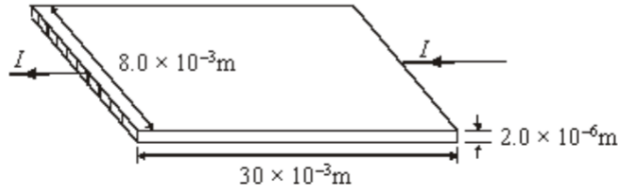

Figure 1

- i) Calculate the resistance of the carbon film to a current I passing through it as shown in Figure 1.

resistivity of carbon = $4.0 \times 10^{-5} \Omega \text{ m}$

- ii) Without recalculating the resistance of the carbon film, explain how you would expect the resistance to change if the current flowed as in Figure 2. You should consider the numerical ratio or factor by which each dimension affecting the resistance has changed.

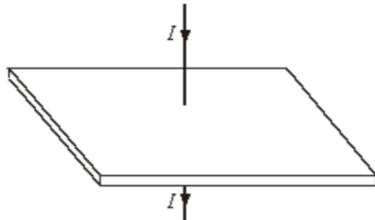

Figure 2

Resistance and Temperature

Exam Style Question 12

- a) Give an expression for the resistivity of a material in the form of a uniform wire. Define all the symbols used.

$$\rho = \frac{RA}{L}$$

Where:

R = resistance of the wire

A = cross-sectional area

L = length of wire

- b) Calculate the resistance of the carbon film to a current I passing through it as shown in Figure 1.

Use: $R = \frac{\rho L}{A}$

To get A we need to calculate the area of the shaded part where I is going into and coming out from:

$$A = (8.0 \times 10^{-3} \text{ m})(2.0 \times 10^{-6} \text{ m}) = 1.6 \times 10^{-8} \text{ m}^2$$

So:

$$R = \frac{(4.0 \times 10^{-5} \Omega \text{ m})(30 \times 10^{-3} \text{ m})}{1.6 \times 10^{-8} \text{ m}^2}$$

$$R = 75 \Omega$$

- bii) explain how you would expect the resistance to change if the current flowed as in Figure 2.

Using $R = \frac{\rho L}{A}$ there is no change in ρ however the length has decreased causing the resistance to decrease. The cross-sectional area, the current goes through has increased, so again resistance decreases. Each dimension changed by a factor of 1.5×10^3 .

This is because the new cross-sectional area will be $A_{new} = (8.0 \times 10^{-3})(30 \times 10^{-3}) = 2.4 \times 10^{-4} \text{ m}^2$. Therefore the factor will be $\frac{2.4 \times 10^{-4} \text{ m}^2}{1.6 \times 10^{-8} \text{ m}^2} = 15000$. The length also changes by a factor of 1.5×10^3 because the new length will be 2.0×10^{-6} therefore $\frac{30 \times 10^{-3}}{2.0 \times 10^{-6}} = 15000$.

Superconductors (AQA and Edexcel Only)

Exam Style Question 13

- a) Some materials exhibit the property of superconductivity under certain conditions.
- State what is meant by superconductivity.
 - Explain the required conditions for the material to become superconducting.
- b) The diagram below shows the cross-section of a cable consisting of parallel filaments that can be made superconducting, embedded in a cylinder of copper.

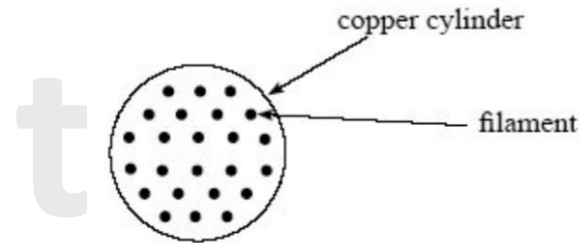

- i) The cross-sectional area of the copper in the cable is $2.28 \times 10^{-7} \text{ m}^2$. The resistance of the copper in a 1.0 m length of the cable is 0.075Ω . Calculate the resistivity of the copper, stating an appropriate unit.
- ii) State and explain what happens to the resistance of the cable when the embedded filaments of wire are made superconducting.



Superconductors (AQA and Edexcel Only)

Exam Style Question 13

- a) State what is meant by superconductivity. Explain the required conditions for the material to become superconducting.

Superconductivity means a material has zero resistivity/resistance. You can lower the resistivity of many materials by decreasing the temperature or cooling them down. If you cool some materials down to below a critical temperature called the 'transitional temperature', their resistivity disappears entirely and they become a superconductors.

- bi) Calculate the resistivity of the copper, stating an appropriate unit.

Use: $R = \frac{\rho L}{A}$ and rearrange for ρ

$$\rho = \frac{RA}{L} = \frac{(0.075 \Omega)(2.28 \times 10^{-7} \text{ m}^2)}{(1 \text{ m})}$$
$$\therefore \rho = 1.7 \times 10^{-8} \Omega \text{ m}$$

- bii) State and explain what happens to the resistance of the cable when the embedded filaments of wire are made superconducting.

The resistance decreases to zero. The copper still has resistance but this is in parallel with filaments (which have zero resistance) hence total resistance is zero and the current goes through the filaments.

Please see '**3.2.1 Resistance and Resistivity notes**' pack for revision notes.

For more revision notes, tutorials and worked examples please visit www.tutorpacks.co.uk.

