



# AS Level Physics

Chapter 7 – Electricity

7.3.1 Resistance and Resistivity

Notes

## RESISTANCE

- A current will flow if you apply a potential difference (p.d.) across an electrical component. The p.d. is what pushes the current through a component.
- The resistance of a component is what determines how much current we can get for a particular p.d.
- So, resistance can be thought of as a measure of how difficult it is to allow current to flow through a component.
- Resistance is a result of charge carriers (usually electrons) repeatedly colliding with each other and the fixed positive ions in a material.

The resistance (R) of a component is the ratio of the p.d. (V) across it to the current (I) flowing through it. It is defined by the equation:

$$\text{Resistance} = \frac{\text{potential difference across component}}{\text{current through component}}$$

$$R = \frac{V}{I}$$

Where:

**R = Resistance** measured in **Ohms,  $\Omega$** .

**V = Potential difference, or Voltage** measured in **Volts, V**.

**I = Current** measured in **Amperes or Amps, A**.

- The unit of resistance (R) is the Ohms ( $\Omega$ ) which is defined as:

**A conductor has a resistance of 1 OHM ( $\Omega$ ) when the p.d. across it is 1 VOLT (V) and the current flowing through is 1 AMP (A).**

$$1\Omega = 1\text{ V A}^{-1}$$

## OHM'S LAW

**Ohms law states that the potential difference across a metallic conductor is proportional to the current through it, as long as the physical conditions (i.e. temperature) remain constant.**

$$V \propto I$$

This means that if you plot a p.d. against current graph, for a metallic conductor, you will get a straight line through the origin. Therefore, regardless of the current, the resistance is the same. This is because the resistance is equal to the gradient of the graph, which is constant and equal to p.d./current at any point. That is only true if the physical conditions are kept constant.

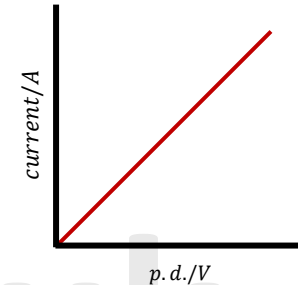

The current flowing through an **ohmic conductor** is proportional to the p.d. that pushes it. As a result, it follows Ohms law and so for this conductor  $V = IR$ .

An **ohmic conductor** yields a **straight line through the origin** for a p.d. against current graph as shown above.

A **non-ohmic conductor** is one which does NOT obey ohm's law.

## Measuring Resistance

- Fixed resistors are designed to have a constant resistance regardless of the current flowing through it. The circuit shown opposite can be used to measure the resistance of a resistor.

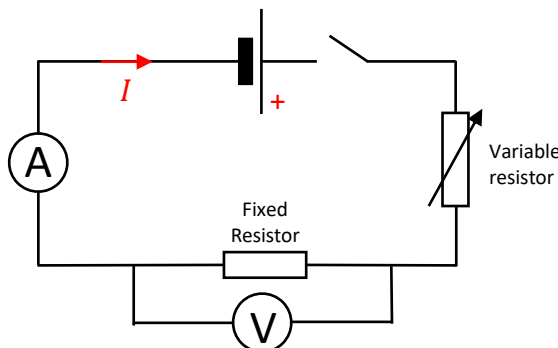

- The ammeter, A, must be connected in series with the resistor and is used to measure the current flowing through the resistor. The same current will flow through both the resistor and the ammeter.
- The voltmeter, V, must be connected in parallel with the resistor so that they both have the same p.d. The voltmeter is used to measure the p.d. across the resistor. No current should flow through the voltmeter; otherwise the ammeter will not accurately record the current flowing through the resistor.
- The voltmeter, should, in theory, have infinite resistance. But, a voltmeter with a sufficiently high resistance is satisfactory.
- The variable resistor\* is used to adjust the current and p.d. as necessary and is also changed in steps to explore the variation of current with p.d. (\*The resistance of a variable resistor can be changed from zero to a particular maximum value. The varying resistance in a circuit can increase or decrease the current/voltage. This can be used to control devices such as dimmer switches.)
- The current and p.d. are measured and recorded using an ammeter and voltmeter at each step. The measurements can then be plotted on a graph of p.d. vs. current, as shown. Here, the gradient is:

$$\text{gradient} = \frac{\text{current}}{\text{voltage}} = \frac{I}{V} = \frac{1}{R}$$

tutorpacks.co.uk

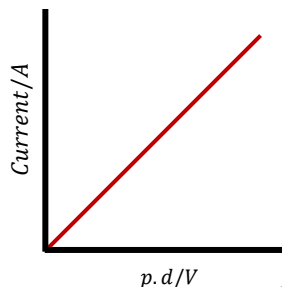

## Current – Voltage (I/V) Characteristic Graphs

- A graph that shows how the current ( $I$ ) flowing through a component (e.g. filament lamp, diode, etc...) changes as the p.d. ( $V$ ) across it rises is called the 'I/V characteristic'.
- The lower the resistance of a component, the steeper the gradient of a characteristic I/V graph.

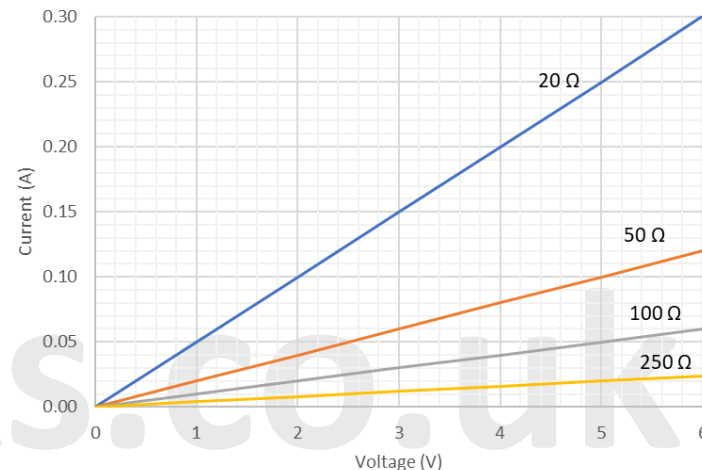

- A straight line on an I/V characteristic graph means the resistance is constant. However, a curve shows that the resistance is changing.
- You can obtain multiple I/V characteristic graphs by simply changing the fixed resistor in the below circuit with a different component such as a:
  - A wire (at constant temperature)
  - Filament Lamp
  - Diode
  - Thermistor
  - Light-dependent resistor (LDR)
  - Light-emitting diode (LED)

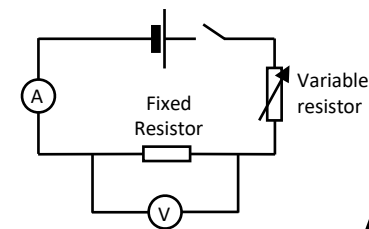

tutorpacks.co.uk



## Current – Voltage (I/V) Characteristic Graphs

### Fixed Resistor or Wire at Constant Temperature

- A fixed resistor or wire (or metallic conductors) at constant temperature obey Ohm's law, making them ohmic conductors. This means that the current is directly proportional to the voltage. As a result, an I/V graph produces a straight line passing through the origin.
- A straight line graph indicates that the resistance remains constant as long as the temperature doesn't change.
- The I/V characteristic graph can have both negative and positive values. In order to obtain the negative values invert the power supply connections.

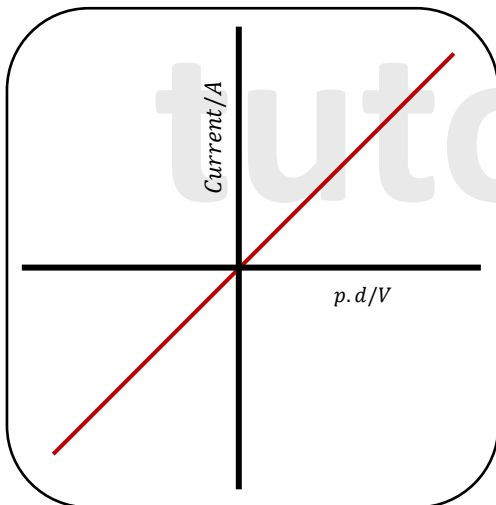

$$\text{Gradient of the I/V graph} = \frac{1}{R}$$

Sometimes p.d. is plotted along the y-axis and current along the x-axis. When this is the case:

$$\text{Gradient of the V/I graph} = R$$

## Current – Voltage (I/V) Characteristic Graphs

### Filament Lamp

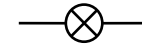

- A filament lamp is a non-ohmic conductor since it does not obey Ohm's law.
- A filament lamps' characteristic graph is a curve that starts off steep but gradually gets flatter as the voltage rises.

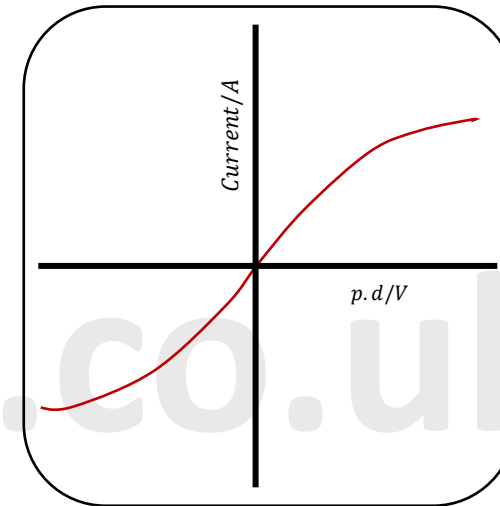

- The filament in a lamp is simply a coiled up piece of metal wire, so you might expect it to have the same characteristic graph as a metallic conductor, but it doesn't. This is because the filament heats up and so the temperature is not constant.
- The filament resistance rises as the p.d. rises. This is because when the p.d. across the filament rises, the temperature increases, forcing the metal atoms to vibrate with higher amplitudes, creating more resistance to electron flow (i.e. current).
- As a result, the resistance of a filament lamp rises as the temperature rises.



## Current – Voltage (I/V) Characteristic Graphs

### • Semiconductors

Semiconductors are not as effective at conducting electricity as metals.

This is due to the fact that there are significantly fewer charge carriers available.

But, when energy is provided to the semiconductor, it releases more charge carriers.

This makes them good sensors for detecting changes in their surroundings.

We will focus on these three types of semiconductors:

#### 1) Thermistors



#### 2) Light-dependent resistors (LDR)

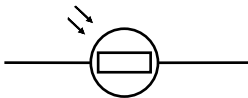

#### 3) Diodes (including light emitting diodes (LEDs))

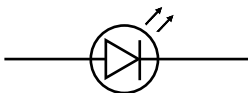

## Current – Voltage (I/V) Characteristic Graphs

### • Thermistors

Thermistors are resistors, whose resistance is dependent on their temperature. Thermistors are non-ohmic conductors that do not obey Ohm's law.

There are two types of thermistors:

- 1) Negative Temperature Coefficient (NTC) thermistors
- 2) Positive Temperature Coefficient (PTC) thermistors

You only need to know about NTC thermistors.

The resistance of NTC thermistors decreases as the temperature increases. The graphs below show the characteristics of NTC thermistors.

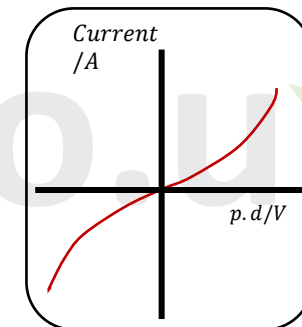
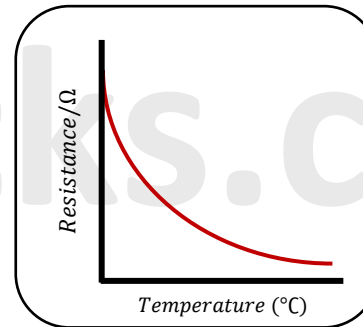

The temperature of the thermistor rises as the current through it increases. The decreasing resistance is indicated by the increasing gradient of this characteristic graph.

When thermistors are heated, electrons gain enough energy and are then able to escape from their atoms.

This results in more charge carriers being available, and therefore the resistance is reduced.

Thermistors can be found in everyday appliances and are commonly used as temperature sensors. Examples include oven, fire alarms, refrigerators and digital thermometers.

Thermistors are also used in a microwaves to determine and maintain their internal temperature. Without a thermistor there is a risk of overheating the unit which could result in a fire.

## Investigating the resistance of a thermistor

Figure 4 shows a circuit for investigating how a thermistor's resistance fluctuates with temperature.

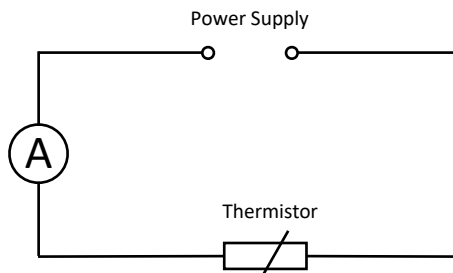

Step 1: Place the thermistor in a beaker and then fill it with enough boiling water to cover the thermistor.

Step 2: Using a digital thermometer and an ammeter measure and record the temperature of the water and current through the circuit respectively. The p.d. across the thermistor need to be kept constant during the experiment.

Step 3: For every  $5^{\circ}\text{C}$  reduction in temperature, continue to record the current and temperature.

Step 4: Calculate the resistance of the thermistor using your recorded values for p.d. and current at each temperature.

Expected result: You should find as the temperature drops, the resistance rises (and therefore the current will decrease). This is only true for an NTC resistor.

## Investigating the resistance of a thermistor

Continue to next page.



## Current – Voltage (I/V) Characteristic Graphs

### • Thermistors

At constant temperature, a thermistor will obey Ohm's law and will produce a straight line on an I/V characteristic graph.

The gradient of the line increases as the temperature rises. This is because the resistance decreases with an increase in temperature.

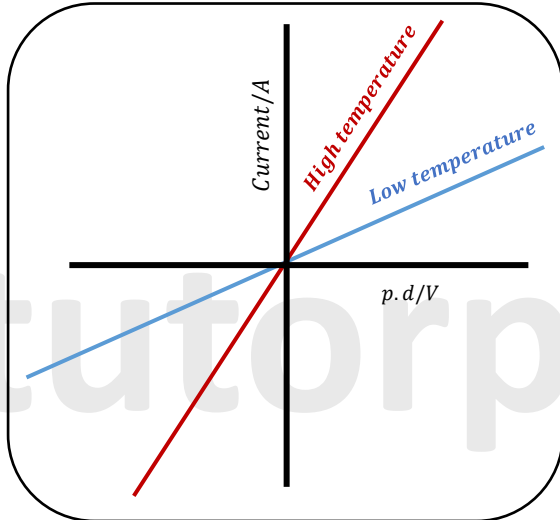

## Current – Voltage (I/V) Characteristic Graphs

### • Light-Dependent Resistor (LDR)

An LDR's resistance is dependent on light intensity.

The resistance of the LDR reduces as the light intensity shining on the LDR increases.

This has a similar explanation as for the thermistor. However, in this case, light is the source of energy that causes the electrons to be released and more charge carriers means a lower resistance.

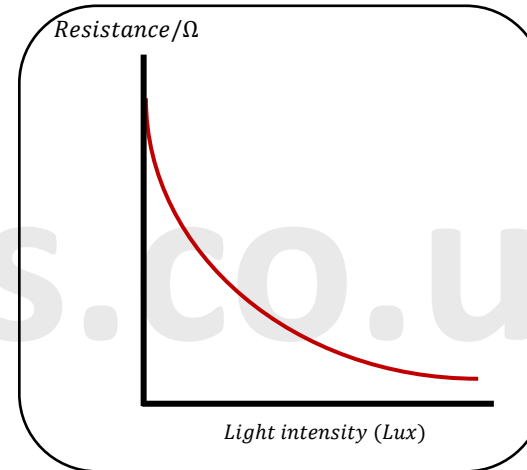

LDRs are most commonly used as light sensors and can be found in street lights, light intensity meters, alarm clocks, etc...

LDRs are used to automatically turn street lights on and off. The LDR can detect light, and the resistance of the LDR decreases significantly with daylight and this idea can be used in a circuit to control the street lights.



## Current – Voltage (I/V) Characteristic Graphs

### • Diodes

A diode (including light emitting diode (LEDs)) are designed to let current flow in one direction.

The current is allowed to flow in the forward direction (forward bias).

A threshold voltage of roughly  $0.7\text{ V}$ , in the forward direction, is required for most diodes to allow current to flow.

The diodes resistance is very high in the reverse direction (reverse bias), and only a small current flows.

### • Light Emitting Diode (LED)

An LED is a semi-conductor diode that emits light when a large enough current flows through it.

An LED is a non-ohmic conductor and doesn't obey Ohm's law.

Below is an I/V graph for a typical LED. The graphs positive side is obtained when the LED is 'forward bias'.

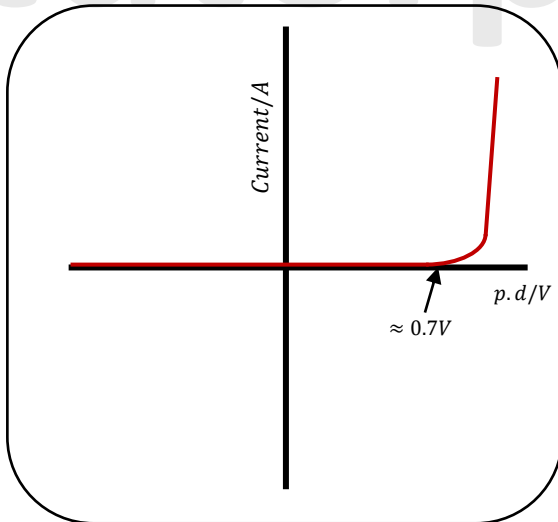

tutorpacks.co.uk

## Current – Voltage (I/V) Characteristic Graphs

### • Diodes

The I/V characteristic graph shows:

- The current flowing through the LED is approx.  $0\text{ A}$  for p.d. less than  $0.7\text{ V}$ , therefore the LED has nearly infinite resistance. At its threshold p.d. ( $\approx 0.7\text{ V}$ ), the LED begins to allow current to flow, and its resistance decreases significantly.
- By inverting the connections to the supply, the negative side of the graph can be produced. The LED is then described as having a 'reverse bias'. It then has nearly infinite resistance and only allows a very small current to pass through it. This means that the LED does not emit light.

Different LED's emit light of different wavelengths (different colours).

LEDs are used for various applications such as:

- LED displays
- Automotive lighting
- Dimming of lights
- TV Backlighting
- Smartphone Backlighting

### **Advantages of LEDs:**

- Have a long working life
- Switch on instantly
- Requires a low p.d.
- Are very robust
- Can be used as a single indicator or in large arrays to illuminate.

tutorpacks.co.uk





## Resistance and Temperature

A pure metals resistance increases linearly as the temperature rises.

Consider a piece of metal wire with a p.d. applied to it.

At **LOW** temperatures, the electrons can drift past the positive metal ions with relative ease because there are fewer collisions to slow them down. This means that the resistance is low.

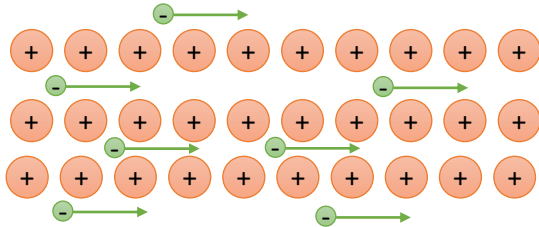

At **HIGHER** temperatures, the positive ions **vibrate with greater amplitude**.

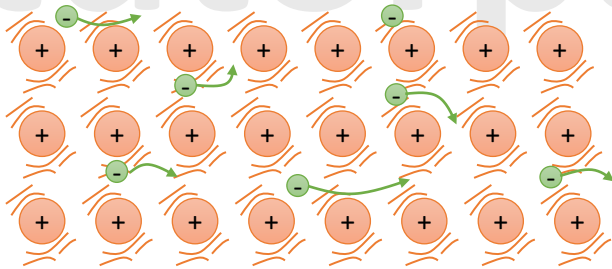

Hence, the electron-ion collisions are more frequent, slowing the flow of electrons (i.e. the current is reduced).

As a result, the **resistance increases with increasing temperature**.

## Resistance and Temperature

An **IMPURE** metals resistance also increases linearly with temperature, but it has a greater increase compared to a pure metal.

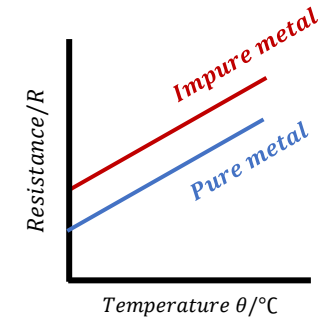
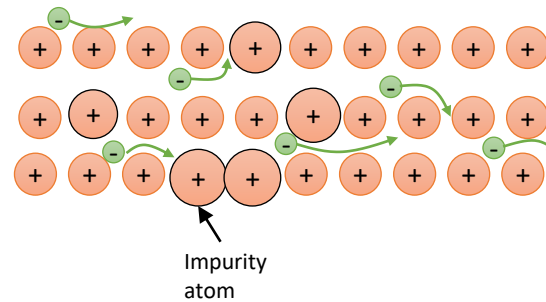

Because the impurity atoms and metal ions are of different sizes, the frequency of collisions experienced by the drifting electrons increases.

The presence of impurity atoms in the metal increases the resistance as they create an additional opposition to the flow of electrons.



## RESISTIVITY ( $\rho$ )

The resistance ( $R$ ) of a wire depends on:

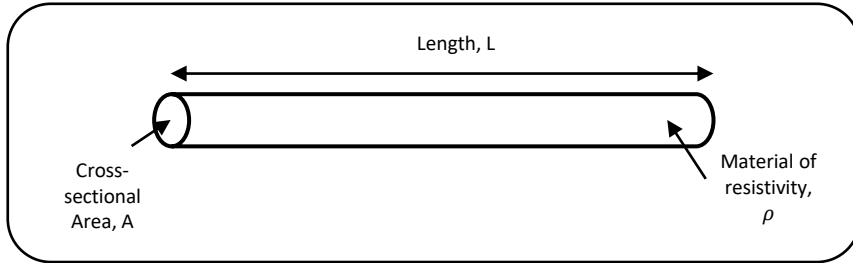

### (1) Length, L

The greater the length,  $L$  (i.e. longer the wire), the greater its resistance,  $R$ .

$$i.e. R \propto L$$

### (2) Cross-Sectional Area, A

The larger the cross-sectional area,  $A$  (i.e. the fatter the wire), the smaller the resistance,  $R$ .

$$i.e. R \propto \frac{1}{A}$$

### (3) Resistivity, $\rho$

Some materials are more resistant to the flow of current than others. Resistivity, represented by the Greek letter rho ( $\rho$ ), takes into account what type of material is used as the wire.

Resistivity is defined as the resistance of a material of unit length with unit cross-sectional area. The unit of measurement is ohm-metres ( $\Omega m$ ).

For a particular material, at a given temperature, the resistivity is constant.

$$i.e. R \propto \rho$$

## RESISTIVITY ( $\rho$ )

We can use the formula below to calculate the resistance,  $R$  of a wire given its length,  $L$ , cross-sectional area,  $A$ , and resistivity,  $\rho$ .

$$Resistance = \frac{Resistivity \times Length}{Cross - sectional area}$$

$$R = \frac{\rho L}{A}$$

Where:

$R$  = Resistance measured in Ohms,  $\Omega$ .

$\rho$  = Resistivity measured in Ohm-metres,  $\Omega m$ .

$L$  = Length measured in metres, m.

$A$  = Cross-sectional area measured in metres squared,  $m^2$ .

Rearrange the above formula for resistivity:

$$\rho = \frac{RA}{L}$$

A typical value for a good conductor i.e. copper is  $1.6 \times 10^{-8} \Omega m$ .



## Resistivity and Temperature

A materials resistivity can be affected by a number of factors. Temperature is a significant factor.

- Metal

The resistivity of a metal increases when it is heated. That's because the atoms of the metal vibrate with greater amplitudes as the temperature rises. As a result, conduction electrons are more likely to collide with atoms as they try to move through the metal. When electrons collide, they lose energy, and so we observe an increase in the metals resistivity.

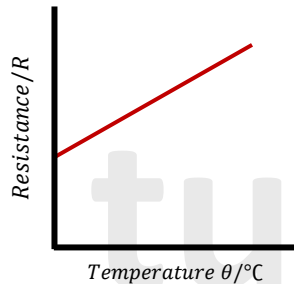

Metal Graph: As the temperature rises, resistance rises with it.

- Semiconductor

The number of conduction electrons in a semiconductor is far lower than in a metal (its number density is low). Electrons in a semiconductor break free from their atoms when the semiconductor is heated. This increases the number of free electrons available to carry the current (and so the number density increases). Therefore, the semiconductors resistivity falls as it is heated.

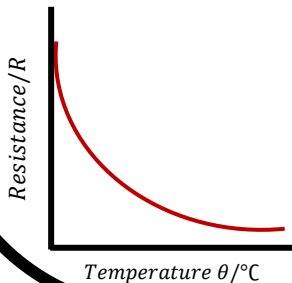

Negative Temperature Coefficient (NTC) Thermistor Graph: over a narrow range of temperature, resistance drops rapidly.

## Resistivity and Temperature

Continue to the next page.



## Superconductors (AQA and Edexcel Only)

All materials, even the best conductors like copper and silver, have some resistivity. This resistance means, they heat up whenever electricity passes through them, wasting some of the electrical energy as heat.

Many materials, such as metals, can be cooled to reduce their resistivity. If materials are cooled below a critical temperature known as the “transitional temperature”, their resistivity disappears completely and they become a superconductor. This is where the material no longer has resistance and so no electrical energy is converted to heat and wasted.

However, the critical temperature of most conductors, such as metals, have a critical temperature below 10 kelvin ( $-263^{\circ}\text{C}$ ) and keeping materials that cold is expensive so we don't use superconductors so often.

Physicists are working on developing room-temperature superconductors, but they are still a long way off.

### **Uses of superconductors**

Superconducting wires can be used to create:

- Strong electromagnets that have lots of applications e.g. in medicine.
- Power cables that transmit electricity without any loss of power.

## Superconductors (AQA and Edexcel Only)

### **Exam Style Question**

- a) Some materials exhibit the property of superconductivity under certain conditions.
- State what is meant by superconductivity.
  - Explain the required conditions for the material to become superconducting.
- b) The diagram below shows the cross-section of a cable consisting of parallel filaments that can be made superconducting, embedded in a cylinder of copper.

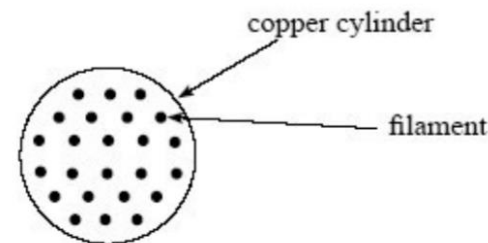

- i) The cross-sectional area of the copper in the cable is  $2.28 \times 10^{-7} \text{ m}^2$ . The resistance of the copper in a  $1.0 \text{ m}$  length of the cable is  $0.075 \Omega$ . Calculate the resistivity of the copper, stating an appropriate unit.
- ii) State and explain what happens to the resistance of the cable when the embedded filaments of wire are made superconducting.



Please see **'7.3.2 Resistance and Resistivity worked examples'** pack for exam style questions.

For more revision notes, tutorials and worked examples please visit [www.tutorpacks.co.uk](http://www.tutorpacks.co.uk).

