



AS Level Physics

Chapter 4 – Waves

4.3.1 Superposition

Notes

Superposition

When two or more waves meet and pass through each other, superposition occurs.

During superposition waves combine for a brief moment, at the point where they meet, before moving apart. Therefore:

The Principle of Superposition states that when two waves meet, the total displacement at a point equals to the sum of the individual displacements at that point.

For example:

A supercrest is formed when a crest meets another crest; the two waves enhance one other.

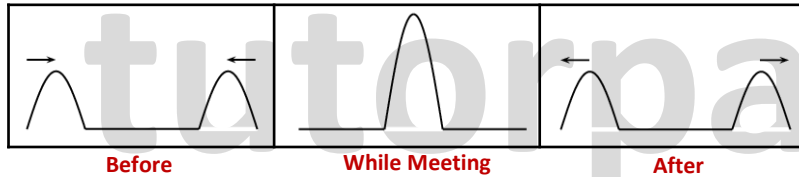

A supertrough is formed when a trough meets another trough; again the two waves enhance each other.

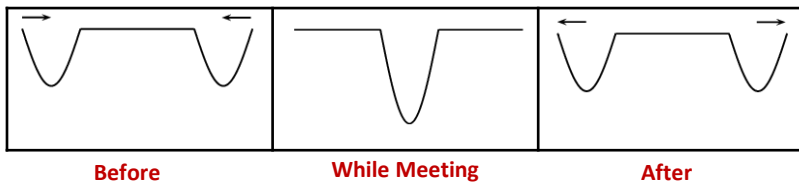

When a crest meets a trough, the resultant displacement is zero; and so waves cancel each other out.



Graphical Representation of Superposition

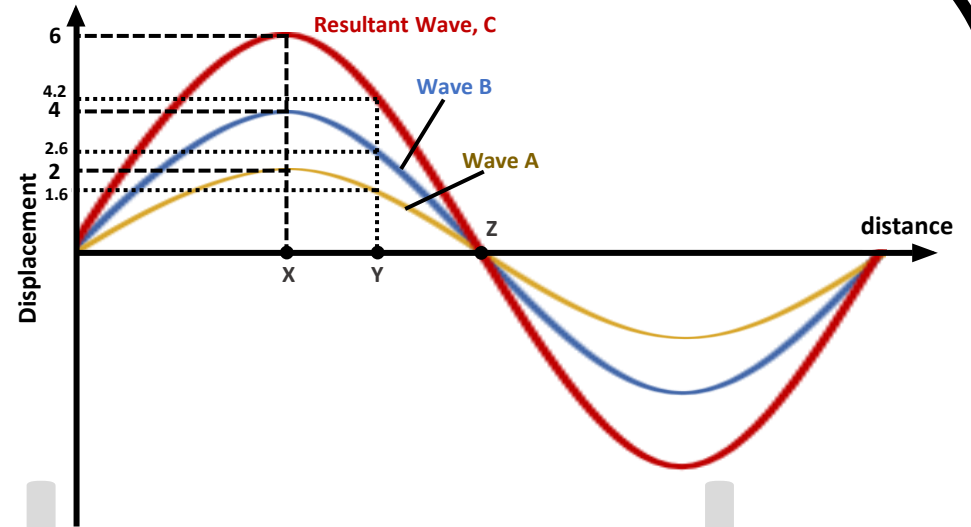

Take a look at the diagram above. When the principle of superposition is applied Wave A and Wave B combine to produce a Resultant Wave C. The shape of Wave C is determined by adding the displacements of A and B at any given point. For example:

At point X:

$$\text{Resultant displacement} = A + B = 2 + 4 = 6$$

At point Y:

$$\text{Resultant displacement} = A + B = 1.6 + 2.6 = 4.2$$

At point Z:

Both A and B have zero displacement and so,

$$\text{Resultant displacement} = A + B = 0$$



Interference

Sound waves

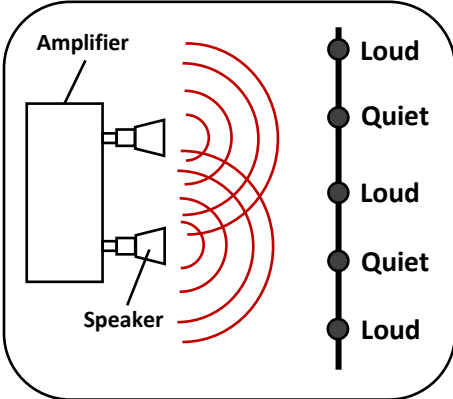

As shown opposite, two loudspeakers are linked to an amplifier. The two speaker's sound waves are of equal frequency, wavelength, and amplitude. In the region in front of the speakers, an interference effect can be observed due to the superposition of sound waves.

The waves arrive **IN PHASE** with each other at some regions, producing a resultant wave which is twice the amplitude of each individual wave. This results in **A LOUD** sound being heard at those regions.

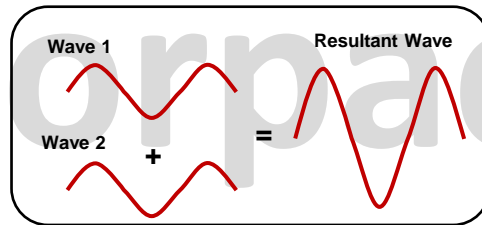

At other times, the waves arrive in **ANTIPHASE** with one another, producing a resultant wave with zero or extremely little amplitude. A **VERY QUIET** sound can be heard at such regions.

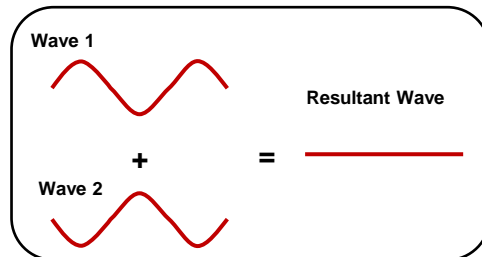

At points in between **LOUD** and **QUIET**, the waves are somewhere in between being **IN PHASE** and **ANTIPHASE**, thus the sound intensity heard is somewhere between **LOUD** and **QUIET**.

Constructive and Destructive Interference

Constructive

Constructive interference is when waves arrive **IN PHASE** and the waves reinforce with each other, producing a resultant wave with a larger amplitude.

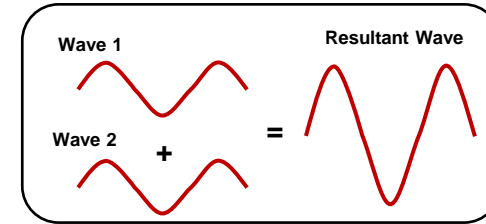

Destructive

Destructive interference is when waves come in **ANTIPHASE** with one another, cancelling each other out, thereby producing a resultant wave of zero amplitude.

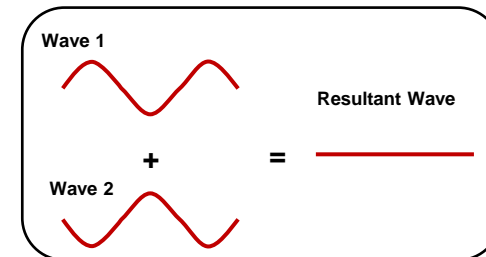

Path Difference

The path difference determines whether the interference is constructive or destructive.

Take our earlier example of sound waves being created by two speakers connected to an amplifier.

How much further one wave has travelled than the other wave to reach a point determines whether you get constructive or destructive interference.

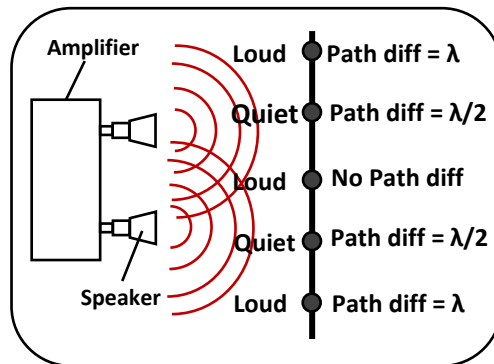

The path difference is the difference between the distance travelled by one wave and the distance travelled by the other wave.

When the two waves have **travelled the same distance**, at any point, you will obtain **constructive interference**. At those points you will get a **path difference** equal to a **whole number of wavelengths**. The two waves will be in phase at this point and will reinforce each other.

Constructive interference occurs when:

$$\text{path difference} = n\lambda \text{ (where } n \text{ is an integer, } \lambda \text{ is wavelength)}$$

The waves arrive **out of phase** at points where the **path difference** is **half a wavelength**, one and a half wavelength, two and a half wavelength, and so on, resulting in **destructive interference**.

Destructive interference occurs when:

$$\text{path difference} = \frac{(2n + 1)\lambda}{2} = \left(n + \frac{1}{2}\right)\lambda$$

Phase Difference

Two waves can be IN PHASE with each other, but so can two points on a wave.

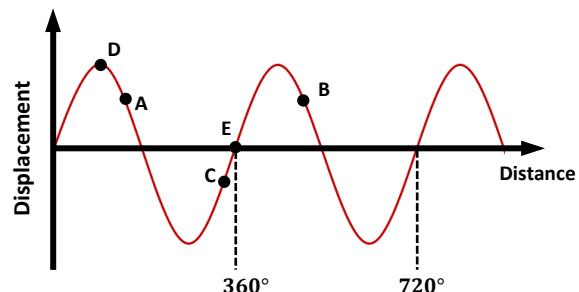

If two points on a wave are at the same point in the wave cycle, they are in phase. The displacement and velocity of those points are the same. On the graph, Points A and B are in phase, but points A and C are out of phase.

Phase difference is expressed as a fraction of cycle, or radians (rad) or degrees ($^{\circ}$).

- 1 cycle = 1 complete wave = $2\pi \text{ rad} = 360^{\circ}$
- $\frac{1}{2}$ cycle = half a wave = $\pi \text{ rad} = 180^{\circ}$
- $\frac{1}{4}$ cycle = quarter of a wave = $\frac{\pi}{2} \text{ rad} = 90^{\circ}$

Two points that are in phase have a phase difference of zero or a multiple of 360° .

Points that have a phase difference of odd-number multiples of 180° (π rads) are exactly out of phase.

For two points separated by distance d along a wavelength, λ , of a wave,

$$\text{phase difference, in radians} = \frac{2\pi d}{\lambda}$$

Point D and E can be seen in the wave above. As you can see, point D is $\frac{1}{4}$ of a wavelength away from the origin, while point E is a full wavelength away. If wavelength is represented by lambda, λ , then point D's distance from the origin is $\frac{1}{4}\lambda$ and point E's distance is simply λ . As a result, the phase difference in radians relative to the origin is:

$$\text{Point D: phase difference} = \frac{2\pi\left(\frac{1}{4}\lambda\right)}{\lambda} = \frac{1}{2}\pi \text{ rads}$$

$$\text{Point E: phase difference} = \frac{2\pi(\lambda)}{\lambda} = 2\pi \text{ rad}$$



Interference

Water Waves

A ripple tank can be used to observe water wave interference.

Two ball-ended dippers vibrate on the water's surface, producing two sets of circular waves with the same frequency and amplitude.

Interference effects may be observed in the resulting wave pattern on the water.

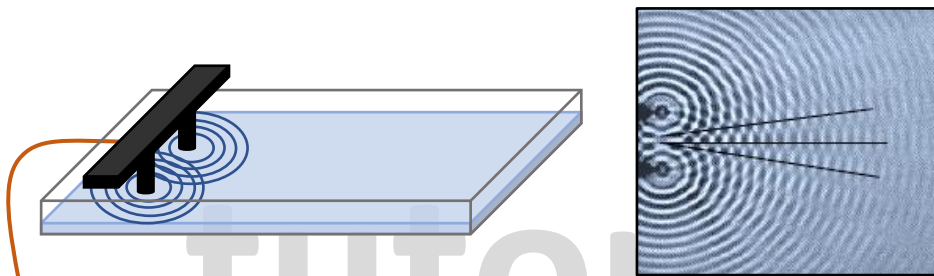

Consider the diagram opposite. There is an interference effect when the water waves intercept. The solid red lines indicate crests, while the dashed red lines represent troughs of the water waves.

There are some points (such as X and Y) where the interfering waves are in phase with each other (i.e. a crest/trough is superposed with a crest/trough) and constructive interference occurs. This results in a wave of great amplitude. Constructive interference occurs along the solid green lines.

There are some points (e.g. Z) where the interfering waves are in antiphase (i.e. a crest is superposed with a trough) and destructive interference occurs. This results in almost complete cancellation of the waves. Along the blue dashed lines destructive interference takes place.



Interference

Water Waves

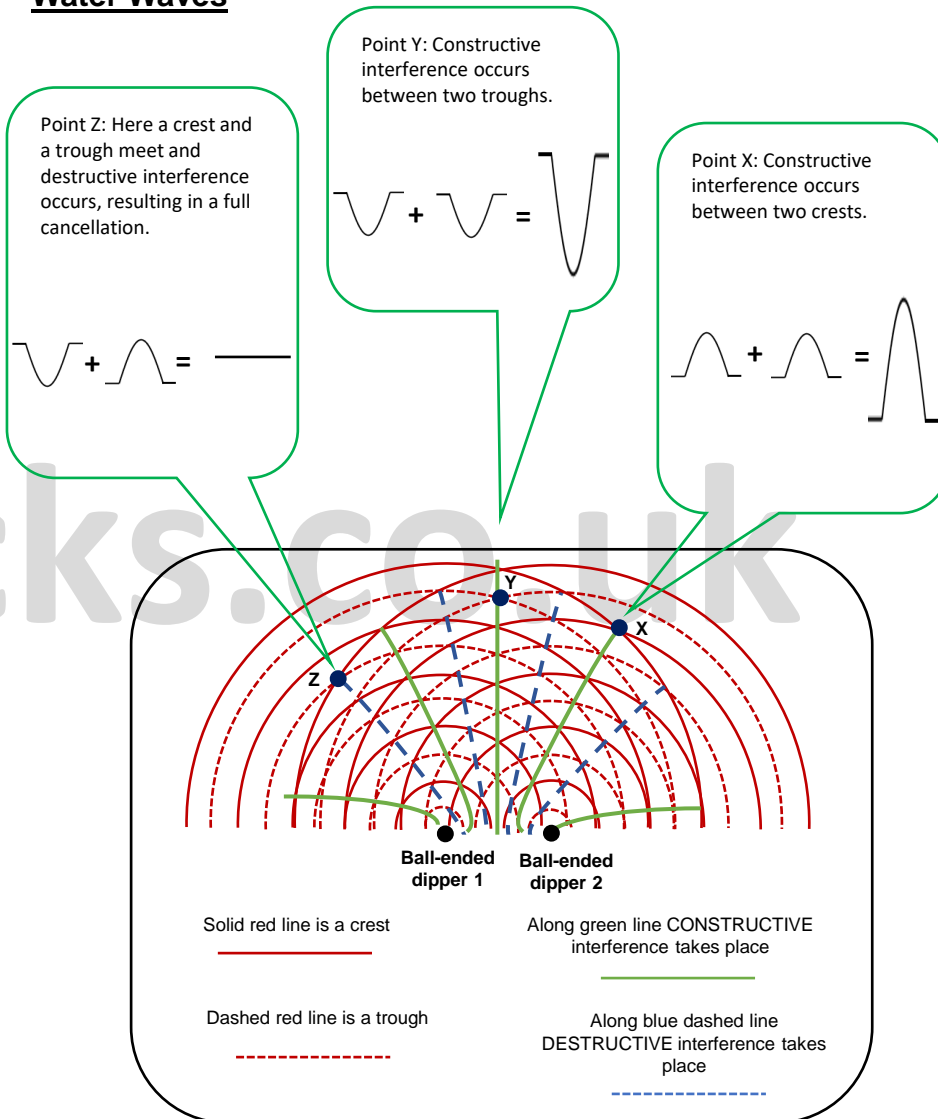

Interference

Microwaves

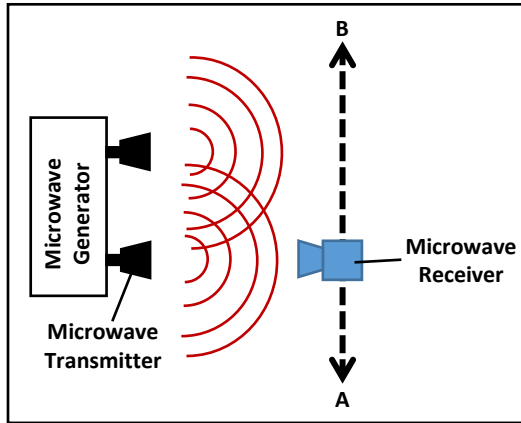

Microwaves can also produce an interference pattern.

To observe the interference pattern you need to connect two microwave transmitters to the same signal generator.

A microwave receiver needs to be travelling along the AB path.

As the microwave receiver moves along the AB path, it records readings, resulting in alternating patterns of strong and weak signals, similar to how loud and quiet sound is produced by using two speakers.

A high value indicates a strong signal, meaning constructive interference.

A low value indicates a weak signal, meaning destructive interference.

Young's Double-Slit Experiment

Light Interference

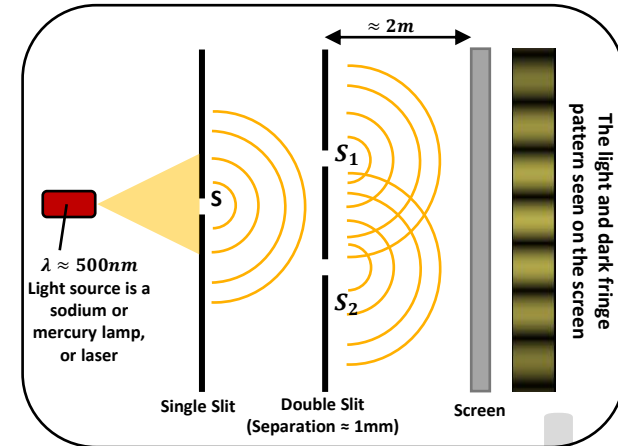

- Light can demonstrate interference too.
- In 1801 Thomas Young demonstrated light interference, and the diagram opposite shows a more modern version of his apparatus.
- The sodium lamp is used as a monochromatic light source (which means it has a single wavelength and frequency, and thus one colour). The monochromatic light is shone through a narrow single slit (S). The light diffracts at S, which produces a diverging beam of light to shine on the two narrow slits S_1 and S_2 , which are parallel to S. Since they are derived from a single source S, the two slits act as coherent light sources (meaning there is a constant phase difference between the waves).
- In the region beyond the slits, the diffracted light beams from S_1 and S_2 overlap, and the superposition of the light waves produces an interference pattern of bright and dark fringes (as shown above). This pattern can be observed on a white screen located approx. 1 – 2m from the double slits.



Interference

Light Interference

Note:

- If a non-monochromatic light is used, the different wavelengths of the light will diffract by different amounts producing a pattern which will not be very clear.
- The slits must be extremely narrow, therefore very little light is transmitted, resulting in a very faint interference pattern that can only be seen in a darkened room.
- A modern version of the apparatus uses a laser that shines a coherent light directly at the double slits, producing an interference pattern that is visible in daylight.
- Remember: In a laser the light is focused into a highly direct, powerful monochromatic beam, so working with them can be quite dangerous. If you stared straight at a laser beam, the lens of your eye would concentrate it into your retina, causing permanent damage. In order to use lasers safely, make sure you:
 - Avoid pointing the laser at a shiny surface
 - Never point the laser at someone
 - When the laser isn't in use, turn it off
 - Wearing laser safety goggles
 - Display a cautionary indication if lasers are being used
- A travelling microscope can be used to measure the fringe separation.
- The fringes become wider but dimmer when the slit-to-screen distance is increased.

Young's Double-Slit Experiment

Please continue to the next page.



Young's Double-Slit Experiment

Explaining the interference fringes

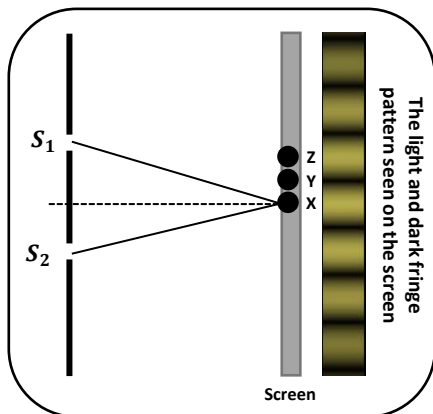

The path difference determines whether you get a constructive or destructive interference at a given point.

Each point on the screen receives light waves from both slits (S_1 and S_2).

- Point X is directly opposite and in between the two slits. This means that the waves leaving slits S_1 and S_2 travel the same distance to reach point X and leave the slits in phase with one another. So, the waves arrive at point X in phase. This is where constructive interference occurs and a bright fringe is produced. The path difference is zero.
- The centre of the first dark fringe is Point Y. The distance travelled by waves from S_1 is shorter than that of waves from S_2 . Therefore, the waves arrive out of phase with one another at Point Y. As a result destructive interference occurs and a dark fringe is produced. The difference in paths is $\lambda/2$.
- The centre of the following bright fringe is Point Z. The two waves arrive in phase with one another, yet one has travelled further. The path difference is λ .

Therefore:

- Where the two waves arrive in phase with one another, a bright fringe is produced and

$$\text{path difference} = n\lambda.$$

- Where the two waves arrive out of phase with one another, a dark fringe is produced and

$$\text{path difference} = (n + \frac{1}{2})\lambda.$$

tutorpacks.co.uk

Young's Experiment was Evidence for the Wave Nature of Light

- Two fundamental theories of light were published at the end of the 17th century, one by Isaac Newton and the other by Huygens. Light, according to Newton's theory, is made up of small particles called "corpuscles." Huygens proposed a theory based on waves.
- Reflection and refraction might be explained by the corpuscular theory, but diffraction and interference are both wave qualities. If light could be demonstrated to have interference patterns, the debate may be put to rest once and for all that light is a wave.
- Young's double-slit experiment (conducted more than a century later) provided the essential proof. It demonstrated how light might diffract (through the narrow slits) and also interfere (to form the interference pattern on the screen).
- However, this isn't the complete story. We will talk more about light being a particle or a wave on a later pack.



tutorpacks.co.uk

Double-Slit Formula

The Young's double-slit experiment provides a method for calculating λ , which is related to the screen distance, D , slit separation, a , and the fringe width, x , by:

$$\lambda = \frac{ax}{D}$$

Where:

λ = light wavelength (m)

a = slit separation (m)

x = fringe width (m)

D = screen distance from slits (m)

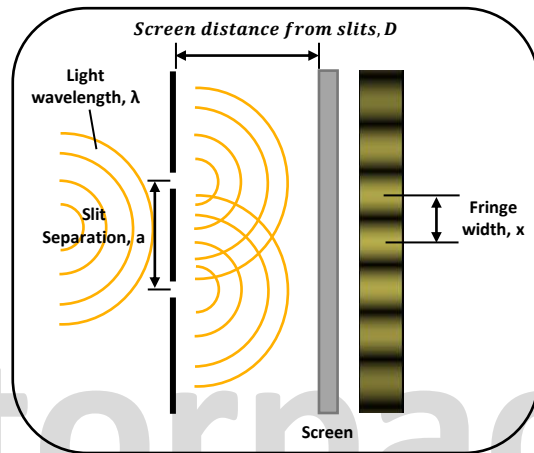

Please note white light is made up of the visible spectrum which contains different colours ranging from red to violet and each colour has a different wavelength, λ ranging from 750 nm to 400 nm . For that reason, using the above formula we can only obtain the average value of λ for a white light.

Laser light, on the other hand, is monochromatic (and so only has a single wavelength), so the fringes are more visible and a more accurate value of λ may be determined.

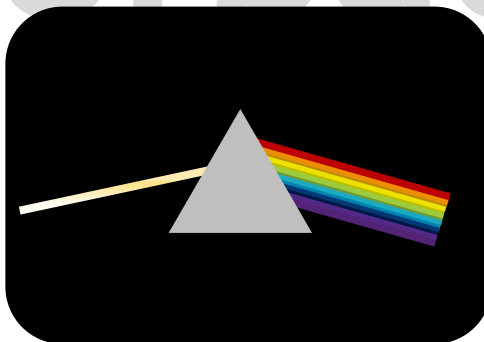

You can find the fringe width by rearranging the formula above or measuring across numerous fringes and dividing by the number of fringe widths between them.

COHERENT SOURCES

The interference pattern must be stable for the interference effects to be visible (i.e. it must not change with time).

This only happens if the wave sources are **IN PHASE** with each other or if the phase difference between them is constant. Such wave sources are said to be **COHERENT**. This also implies that the sources have the same frequency.

Therefore a coherent source is one that has a constant phase difference between the waves.

Examples of coherence

- Laser light
- For microwave/light interference, the two slits emit waves derived from the same source.
- The vibrating dippers in a ripple tank are in phase because they are driven by the same source.

Conditions for observable interference

- The term "coherent wave sources" refers to sources that have the same frequency. If the frequency keeps changing the interference pattern will continually change and the effect won't be visible.
- To ensure good contrast between the bright and dark fringes, the interfering waves should have about the same amplitude.



Diffraction Grating

A diffraction grating is a small glass plate with a large number of equally spaced parallel slits.

For example:

A double slit contains only two slits, however a diffraction grating can have up to a 100 slits that are all equally spaced, parallel, and close together, as seen in the diagram opposite:

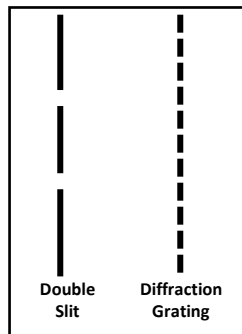

We use a diffraction grating with many slits because it produces bright fringes that are more widely separated. A double-slit arrangement, produces dim and blurred bright fringes that blend into the black fringes, making precise measurements difficult to obtain. We can perform more precise measurements with the diffraction grating.

As you can see below, a diffraction grating generates highly distinct dots on the screen, whereas a double slit blends the bright and dark fringes together, making it difficult to tell where the bright fringe ends and the dark fringe begins:



Pattern Obtained when using a diffraction grating



Pattern Obtained when using double slits

Diffraction Grating

Intensity graphs

The intensity is highest in the centre of the pattern in both the diffraction grating and the double slit. However the intensity gradually decreases as it moves away from the centre of the pattern in the double slit. This is because as you go away from the pattern's centre, the bright fringes become less and less bright, eventually fading away.

When using a diffraction grating, the intensity is nearly constant throughout the pattern. This is because bright fringes appear as dots when monochromatic light is passed through a grating with hundreds of slits per millimetre. This makes the interference pattern really sharp as there are many beams of light reinforcing the pattern.

Measurements are more accurate when the fringes are sharper.



Pattern Obtained when using a diffraction grating



Pattern Obtained when using double slits

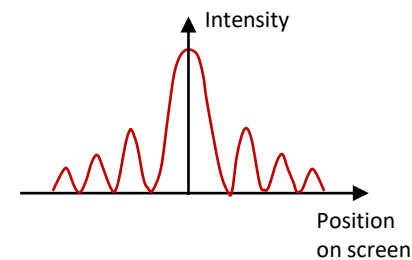
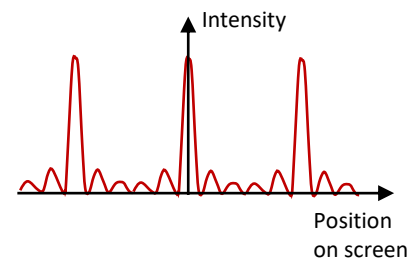

Diffraction Grating

The n^{th} order

All constructive interferences for monochromatic light are extremely sharp, resulting in either clear dots or sharp lines, as shown below. White light, on the other hand, is not the same – we will see the difference later in the pack.



When monochromatic light passes through a diffraction grating, clear dots appear.



When monochromatic light goes through a diffraction grating, sharp lines appear.

When monochromatic light enters the diffracting grating, it spreads out due to the numerous slits present.

At the centre, there is a line of maximum brightness produced, which we call the zero order line.

First order lines are the ones on either side of the central one. Second order lines are the following pair out, and so on as shown on the diagram below.

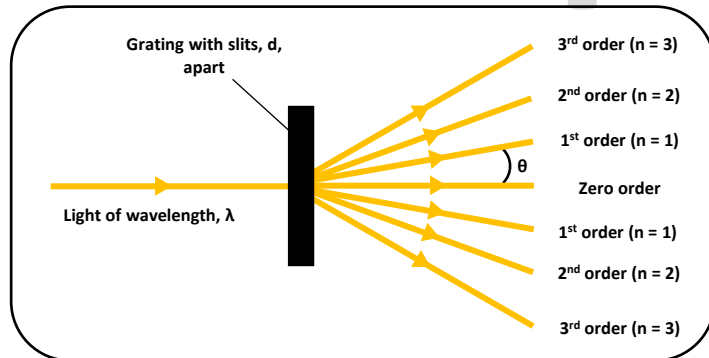

Diffraction Grating

Diffraction Grating Equation

The angle between the incident beam and the n^{th} order constructive interference fringe for a diffraction grating with slits spaced a distance d , apart is given by:

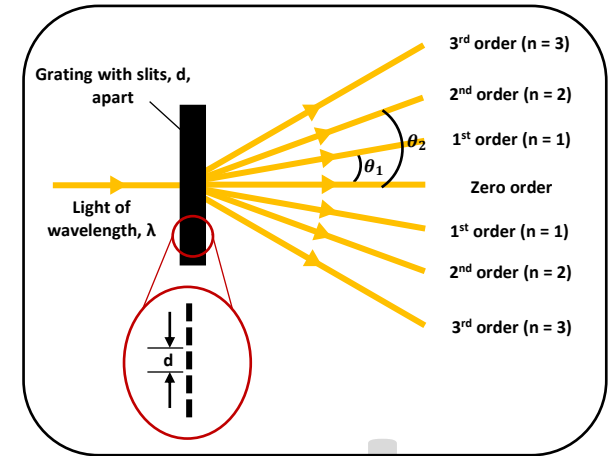

$$d \sin \theta = n \lambda$$

Where:

- d = grating spacing measured in metres (m)
- θ = diffraction angle in degrees (θ_1 = first order angle, θ_2 = second order angle, θ_3 = third order angle, etc...)
- n = the diffraction order (e.g. $n = 0, 1, 2, 3$, etc...)
- λ = light wavelength in metres (m)

The grating spacing (d) is calculated in a slightly different way. As diffraction gratings are usually specified in lines per mm (or slits per mm), we can use $D = \text{lines per mm}$ to calculate grating space (d):

e.g. a diffraction grating has 100 lines per mm calculate grating space (d)

$$d = \frac{1}{D} = \frac{1}{100} = 0.01 \text{ mm} = 1 \times 10^{-5} \text{ m}$$

Derivation of the diffraction grating equation (AQA Only)

You'll have to learn how to derive:

$$d \sin \theta = n \lambda$$

Consider the maximum of the first order ($n=1$ on the previous page). This occurs when the waves from one slit line up with waves from the next slit that are one wavelength behind, as shown opposite.

The angle formed between the diffracted wave (green line) and the incoming light (yellow line) is referred to as θ .

Now look at the triangle highlighted in the diagram. The angle is θ (obtained using basic geometry as shown in the blue rectangle), d is the slit spacing, and the path difference is λ .

So for the first maximum, using trig, $\sin \theta = \frac{\text{opposite}}{\text{hypotenuse}}$,
 $\therefore \sin \theta = \frac{\lambda}{d}$
 $d \sin \theta = \lambda$

So we have the formula for the first order maxima. Other maxima occur when the path difference is $2\lambda, 3\lambda, 4\lambda$, and so on, therefore the n^{th} order maximum occurs when the path difference is $n\lambda$. Simply replace λ in the above formula with $n\lambda$ to make the equation more general, where n is an integer equal to the order of the maxima (the order number)

$$d \sin \theta = n \lambda$$

Derivation of the diffraction grating equation (AQA Only)

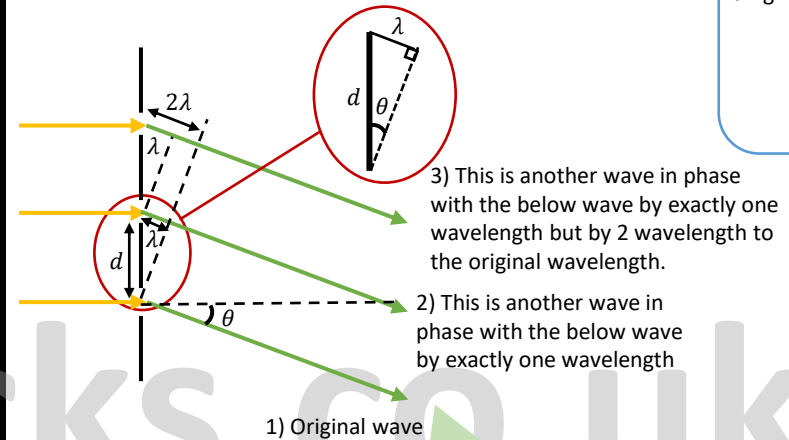

The angle θ is found by looking at angles in a right angled.

3) This is another wave in phase with the below wave by exactly one wavelength but by 2 wavelength to the original wavelength.

2) This is another wave in phase with the below wave by exactly one wavelength

1) Original wave

These parallel light rays will eventually meet and constructively interfere with each other by the time they reach the screen. This is where you will be able to see a dot as a bright fringe. Since the screen is so far away from the grating, the waves appear to be about parallel and you might think they won't intersect.

Diffraction Grating

Diffraction Grating Equation

Knowing the equation you can conclude:

- 1) If λ is bigger, $\sin \theta$ is bigger, and so θ is bigger. This indicates that the pattern will be more spread out as the wavelength increases.
- 2) If d is bigger, $\sin \theta$ is smaller. This means that the closer the grating, the less the pattern will spread out.
- 3) $\sin \theta$ values greater than 1 are impossible. So, if you receive a value of more than 1 for $\sin \theta$ for a given n , you know that order doesn't exist.

Diffraction Grating

Shining white light through a diffraction grating

White light is actually a mixture of colours. When white light is diffracted by a grating, the pattern produced is created because of the different wavelengths present within the white light that are diffracted by different amounts.

Each order in the pattern becomes a spectrum, with red on the outside and violet on the inside. The zero order maximum stays white because all the wavelengths just pass straight through.

The pattern produced is called a Spectra.

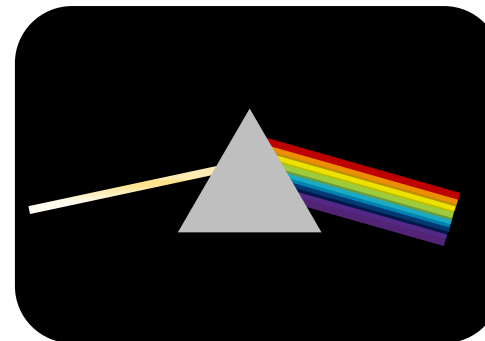
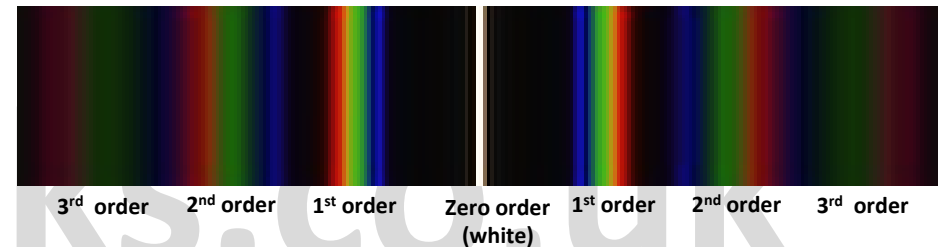

When white light is directed into a prism, it can also produce a spectrum, but a diffraction grating is more accurate.



Example/Applications of Diffraction Grating

Ordinary manufactured CDs are a common example of diffraction grating that may be used to demonstrate the effect by reflecting sunlight off them onto a white wall. This occurs as a result of a manufacturing side effect.

One of the uses of diffraction grating is in X-ray crystallography. X-rays have a wavelength that is comparable to the distance between atoms in crystalline solids. This means that if X-rays are directed on a thin crystal, a diffraction pattern will form. The crystal acts as a diffraction grating, and the diffraction pattern can be used to determine the spacing between the atoms (slit width).

Spectrometers, lasers, optical pulse compression devices, and monochromators are among the other applications for diffraction gratings.



Please see '**4.3.2 Superposition worked examples**' pack for exam style questions.



Please see '**4.3.2 Superposition worked examples**' pack for exam style questions.

For more revision notes, tutorials and worked examples please visit www.tutorpacks.co.uk.

tutorpacks.co.uk

